



# V2V EDTECH LLP

Online Coaching at an Affordable Price.

## OUR SERVICES:

- Diploma in All Branches, All Subjects
- Degree in All Branches, All Subjects
- BSCIT / CS
- Professional Courses



+91 93260 50669



v2vedtech.com



V2V EdTech LLP



v2vedtech

**UNIT-1**

**1. Why is there a sudden increase in current in Zener diode?**

- a) Due to the rupture of ionic bonds
- b) Due to rupture of covalent bonds
- c) Due to viscosity
- d) Due to potential difference

Answer: b

Explanation: The sudden increase in current in a Zener diode is due to the rupture of the many covalent bonds present. Therefore, the Zener diode should be connected in reverse bias.

**2. What is the semiconductor diode used as?**

- a) Oscillator
- b) Amplifier
- c) Rectifier
- d) Modulator

Answer: c

Explanation: Semiconductor diode can be used as a rectifier. The function of a rectifier is that it converts an alternating current into direct current by allowing the current to pass through in one direction.

**3. What is an oscillator?**

- a) An amplifier with a large gain
- b) An amplifier with negative feedback
- c) An amplifier with positive feedback
- d) An amplifier with no feedback

Answer: c

Explanation: An oscillator is considered as an amplifier with positive feedback. It converts direct current from a power supply to an alternating current signal. It produces an alternating waveform without any input.

**4. What is rectification?**

- a) Process of conversion of ac into dc
- b) Process of conversion of low ac into high ac
- c) Process of conversion of dc into ac
- d) Process of conversion of low dc into high dc

Answer: a

Explanation: Rectification is the process of conversion of alternating current into direct current. The conversion first powers to alternating current then use a transformer to change the voltage, and finally rectifies power back to direct current.

**5. What is a Zener diode used as?**

- a) Oscillator
- b) Regulator
- c) Rectifier
- d) Filter

Answer: b

Explanation: Zener diode can be used as a voltage regulator. They can also be used as shunt regulators to regulate the voltage across small circuits. Zener diodes are always operated in a reverse-biased condition.

**6. Forward biasing of p-n junction offers infinite resistance.**

- a) True
- b) False

Answer: b

Explanation: No, this is a false statement. Forward biasing of p-n junction offers low resistance. In the case of an ideal p-n junction, the resistance offered is zero. So, forward biasing does not offer any resistance.

**7. When a junction diode is reverse biased, what causes current across the junction?**

- a) Diffusion of charges
- b) Nature of material
- c) Drift of charges
- d) Both drift and diffusion of charges

Answer: c

Explanation: The reverse current is mainly due to the drift of charges. It is due to the carriers like holes and free electrons passing through a square centimeter area that is perpendicular to the direction of flow.

**8. Identify the condition for a transistor to act as an amplifier.**

- a) The emitter-base junction is forward biased and the base-collector junction is reverse biased
- b) No bias voltage is required
- c) Both junctions are forward biased
- d) Both junctions are reverse biased

Answer: a

Explanation: In order to use a transistor as an amplifier the emitter-base junction is set up as forward biased and the base-collector junction is set up as reverse biased. This is the criteria for making a transistor function as an amplifier.

**9. What can a p-n junction diode be used as?**

- a) Condenser
- b) Regulator
- c) Amplifier
- d) Rectifier

Answer: d

Explanation: A junction diode can be used as a rectifier. The rectifier converts alternating current into direct current. During the positive half cycle, the diode is forward biased and allows electric current through it.

**10. What is a transistor made up of?**

- a) Chip
- b) Insulator
- c) Semiconductor
- d) Metal

Answer: c

Explanation: A transistor is a semiconductor device. Transistors can work either as an amplifier or as a switch. It is used to amplify or switch electronic signals. A transistor is a solid-state device made up of silicon and germanium.

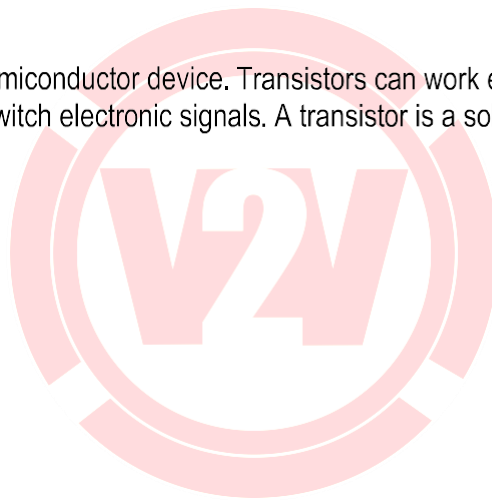

**11. What will happen when a p-n diode**

- a) No current flows
- b) The depletion region is increased
- c) The depletion region is reduced
- d) The height of the potential barrier is reduced

Answer: b

Explanation: When a p-n diode is reverse biased, its depletion region is widened. This is because the voltage at the cathode will be higher than at the anode. This has the effect of increasing or decreasing the effective resistance of the junction itself allowing or blocking current flow through the diode.

**12. What will be the resistance measured by an ohmmeter, if a p-n diode is reverse biased?**

- a) Zero
- b) Low
- c) High
- d) Infinite

Answer: c

Explanation: When a p-n diode is reverse biased, it offers high resistance. Forward biasing of p-n junction diode offers low resistance. In the case of an ideal p-n junction, resistance is zero. So, the ohmmeter can measure zero resistance.

**13. Find out the application of the diode.**

- a) Oscillator
- b) Amplifier
- c) Rectifier
- d) Modulator

Answer: c

Explanation: Diode is used as a rectifier. A rectifier diode allows current to pass in only one direction. A rectifier will be able to convert alternating current into direct current.

**14. Which of the following constitutes Zener diode?**

- a) Oscillator
- b) Regulator
- c) Rectifier
- d) Filter

Answer: b

Explanation: A transistor is a semiconductor device. It can act as a switch as well as an amplifier. Transistors are made up of semiconductor materials like silicon, germanium, etc. It is usually with at least three terminals for connection to an external circuit.

**15. Which of the following**

- a) Chip
- b) Insulator

- c) Semiconductor
  - d) Metal
- Answer: c

**17. What accounts for the flow of charge carriers in forward and reverse biasing of silicon p-n diode?**

- a) Drift in forward bias and diffusion in forward bias
- b) Drift in reverse bias and diffusion in forward bias
- c) Drift in both reverse and forward bias
- d) Diffusion in both forward and reverse bias

Answer: b

Explanation: Drift current flows from n-side to p-side while diffusion current flows from p-side to n-side. In forward biasing, diffusion current is more than the drift current and in reverse biasing, drift current is more than the diffusion current.

**18. Which of the following accounts for the presence of the potential barrier in the depletion layer?**

- a) Ions
- b) Holes
- c) Electrons
- d) Forbidden band

Answer: a

Explanation: The potential barrier in the depletion layer is due to the presence of immobile ions. The acceptor and donor atoms will gain negative and positive charges leading to p-n junction formation. Hence, acceptor and donor are immobile ions.

**19. Which of the following is true in case of the unbiased p-n junction?**

- a) The high potential at n-side and low potential at p-side
- b) The high potential at p-side and low potential at n-side
- c) p and n both are at the same potential
- d) Undetermined

Answer: a

Explanation: In an unbiased p-n junction, the high potential is at the n-side and the low potential at the p-side. When the polarity of the battery is reversed, the p-n junction gets reverse biased and does not conduct electric current.

**20. What causes drift current in a p-n junction diode?**

- a) Electric field
- b) Charge carriers density
- c) Collision of electrons
- d) Electric potential

Answer: b

Explanation: Drift current is due to the high concentration of holes

concentration of electrons in the n-region of the junction diode. The combined effect of the movement of minority charge carriers results in drift current.

**21. On doping germanium metal, with a**

- a) Intrinsic semiconductor
- b) Insulator
- c) n-type semiconductor
- d) p-type semiconductor

Answer: d

Explanation: Indium impurity in germanium produces p-type semiconductors. A trivalent impurity added to germanium produces a p-type semiconductor. Trivalent impurities such as boron, indium, and gallium are called acceptor impurity.

**22. In a pure semiconductor crystal, if current flows due to breakage of crystal bonds, then what is the semiconductor is called?**

- a) Acceptor
- b) Donor
- c) Intrinsic semiconductor
- d) Extrinsic semiconductor

Answer: c

Explanation: Pure semiconductors are called intrinsic semiconductors. The number of electrons in the conduction band will be equal to the number of holes in the valence band. Intrinsic semiconductors are also called undoped and i-type semiconductors.

**23. Which of the following, when added as an impurity, into the silicon, produces n-type semiconductor?**

- a) Phosphorous
- b) Aluminum
- c) Magnesium
- d) Sulfur

Answer: a

Explanation: As phosphorous is pentavalent, it produces n-type semiconductor when added to silicon. They are called donor impurities. By adding phosphorus, extra valence electrons are added that become unbonded from individual atoms.

**24. In n-type semiconductors, which one is the majority charge carriers?**

- a) Holes
- b) Protons
- c) Neutrons
- d) Electrons

Answer: d

such as boron, indium, and gallium are called acceptor impurity. These can be added to germanium order to obtain a p-type semiconductor.

**25. A small impurity is added to germanium to get a p-type semiconductor. Identify the impurity?**

- a) Bivalent substance
- b) Trivalent substance
- c) Pentavalent substance
- d) Monovalent substance

Answer: b

Explanation: A trivalent impurity added to germanium produces a p-type semiconductor. Trivalent impurities

**26. Boron when added as an impurity, into the silicon, produces n-type semiconductor.**

- a) True
- b) False

Answer: b

Explanation: When a pentavalent impurity is added as an impurity to silicon, it produces n-type semiconductor. In n-type semiconductors, electrons are majority charge carriers, whereas the holes are minority charge carriers.

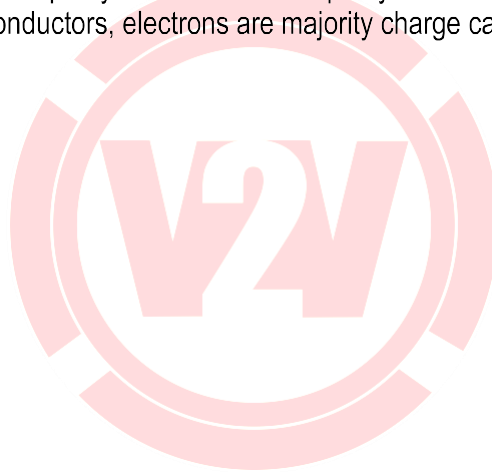



**27. Identify the property which is not characteristic for a semiconductor?**

- a) At a very low temperature, it behaves like an insulator
- b) At higher temperatures, two types of charge carriers will cause conductivity
- c) The charge carriers are electrons and holes in the valence band at higher temperatures
- d) The semiconductor is electrically neutral

Answer: c

Explanation: In a semiconductor, electrons are the charge carriers in the conduction band and holes are the charge carriers in the valence band at higher temperatures. The other statements are not valid.

**28. The n-type semiconductor is which of the following?**

- a) Positively charged
- b) Negatively charged
- c) Neutral
- d) Positive or negative depending upon doping materials

Answer: c

Explanation: Semiconductors maintain their electrical neutrality even after doping. This is achieved by adding an impurity to a pure semiconductor in order to obtain an n-type semiconductor.

**29. The dominant contribution to current comes from holes in case of which of the following?**

- a) Metals
- b) Intrinsic semiconductors
- c) p-type extrinsic semiconductors
- d) n-type extrinsic semiconductors

Answer: c

Explanation: Holes are the majority charge carriers in p-type extrinsic semiconductors. Trivalent impurities such as boron, indium, and gallium are called acceptor impurity. Also, in p-type semiconductors, electrons are the minority charge carriers.

**30. In a p-type semiconductor, germanium is doped with which of the following?**

- a) Gallium
- b) Copper
- c) Phosphorous
- d) Nitrogen

Answer: a

Explanation: Substances such as gallium, boron, and aluminum are all trivalent atoms. These are called acceptor impurities and they produce p-type semiconductors. Therefore, germanium is doped with gallium in a p-type semiconductor.

**31. An intrinsic semiconductor, at the absolute zero temperature, behaves like which one of the following?**

- a) Insulator

**32. The probability of electrons to be found in the conduction band of an finite temperature is which of the following?**

- a) Increases exponentially with the increasing bandgap
- b) Decreases exponentially with the increasing bandgap
- c) Decreases with increasing temperature
- d) Is independent of the temperature and the bandgap

Answer: b

Explanation: At a finite temperature, the probability of jumping an electron from the valence band to the conduction band decreases exponentially with the increasing bandgap ( $E_g$ ). The other options are not valid.

**33. Which of the following statements is not true?**

- a) The resistance of intrinsic semiconductor decreases with the increase of temperature
- b) Doping pure Si with trivalent impurities gives p-type semiconductors
- c) The majority carriers in n-type semiconductors are holes
- d) A p-n junction can act as a semiconductor diode

Answer: c

Explanation: The majority charge carriers in n-type semiconductors are electrons, not holes. It is made by adding an impurity to a pure semiconductor such as silicon or germanium. All the other statements are true.

**34. Holes are charge carriers in which one of the following?**

- a) Intrinsic semiconductors
- b) Ionic solids
- c) n-type semiconductors
- d) Metals

Answer: a

Explanation: In intrinsic semiconductors, the holes are charge carriers.

For intrinsic semiconductors, the expression is given as:

$$n_h = n_e.$$

**35. In semiconductors at a room temperature correspond to which among the following?**

- a) The valence band is partially empty and the conduction band is partially filled
- b) The valence band is filled and the conduction band is partially filled
- c) The valence band is filled
- d) The conduction band is empty

Answer: a

Explanation: When the semiconductors are at room temperature, the valence band of the semiconductor is partially empty, whereas the conduction band of the semiconductor is partially filled with electrons.

- b) Superconductor
- c) n-type semiconductor
- d) p-type semiconductor

Answer: a

**36. A semiconductor is damaged by a strong current because of a lack of free electrons.**

- a) True
- b) False

Answer: b

Explanation: No, this statement is false. When a strong current is passed through a semiconductor, this causes many covalent bonds to break up due to heating and thereby to liberate a large number of free electrons.

**37. At absolute zero, Si acts as which of the following?**

- a) Non-metal
- b) Metal
- c) Insulator
- d) Capacitor

Answer: c

Explanation: At absolute zero temperature, silicon acts as an insulator. This is because, at absolute zero, silicon does not have any free electrons in its conduction band, and therefore, acts as an insulator in the absence of free electrons.

**38. Choose the false statement from the following.**

- a) In conductors the valence and conduction band overlap
- b) Substances with an energy gap of the order of 10 eV are insulators
- c) The resistivity of a semiconductor increases with increase in temperature
- d) The conductivity of a semiconductor increases with increase in temperature

Answer: c

Explanation: Resistivity of a semiconductor and temperature are inversely proportional to each other. When the resistivity of a semiconductor decreases, the temperature increases. Semiconductors have bulk resistivity in the range of  $10^3$ -ohm cm.

**39. At which temperature, a pure semiconductor behaves slightly as a conductor?**

- a) Low temperature
- b) Room temperature
- c) High temperature
- d) Vacuum

Answer: c

Explanation: A pure semiconductor behaves slightly as a conductor at high temperatures. As temperature increases, resistivity decreases, and since resistivity and conductivity are inversely proportional to each other, the conductivity of the intrinsic semiconductor increases with an increase in temperature.

**40. In a pure semiconductor crystal, if current flows due to breakage of crystal bonds, then what is the semiconductor called?**

- a) Acceptor
- b) Donor
- c) Intrinsic semiconductor
- d) Extrinsic semiconductor

Answer: c

**42. The energy band gap is maximum in which of the following?**

- a) Metals
- b) Superconductors
- c) Insulators
- d) Semiconductors

Answer: c

Explanation: The bandgap is maximum in insulators. This makes it difficult for electrons to move to the conduction band. This is contrary to metals and superconductors, which has minimum band gaps facilitating the movement of electrons.

**41. The manifestation of the band structure in solids is due to which of the following?**

- a) Heisenberg's uncertainty principle
- b) Pauli's exclusion principle
- c) Bohr's correspondence principle
- d) Boltzmann's law

Answer: b

Explanation: The electronic configuration of atoms and consequently their manifestation of the band structure of solids can be well explained based on Pauli's exclusion principle.

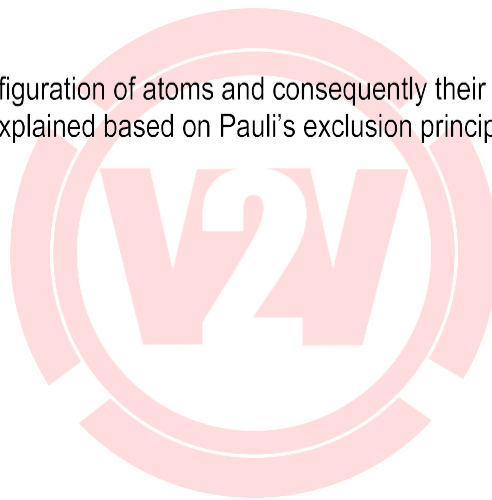

**43. At absolute zero, Si acts as which of the following?**

- a) Non-metal
- b) Metal
- c) Insulator
- d) Superconductor

Answer: c

Explanation: At absolute zero, the element, silicon (Si) acts as an insulator due to the absence of free electrons in the conduction band. The other options are not valid.

**44. A piece of copper and another of germanium are cooled from room temperature to 77 K. what will impact on the resistance of each of them?**

- a) Each of these decreases
- b) Copper strip increases and that of germanium decreases
- c) Copper strip decreases and that of germanium increases
- d) Each of these increases

Answer: c

Explanation: With the decrease of temperature, the resistance of copper, which is a metallic conductor, will decrease, whereas the resistance of germanium, which is a semiconductor will increase.

**45. In semiconductors at room temperature, which of the following is likely to happen?**

- a) The valence band is partially empty and the conduction band is partially filled
- b) The valence band is filled and the conduction band is partially filled
- c) The valence band is filled
- d) The conduction band is empty

Answer: a

Explanation: In semiconductors at room temperature, the valence band is partially empty and the conduction band is partially filled. The other options are not suitable according to the room temperature condition of semiconductors.

**46. At absolute zero temperature, a semiconductor acts as a conductor.**

- a) True
- b) False

Answer: b

Explanation: At absolute zero temperature, a semiconductor does act as an insulator. When the electron gains enough energy to participate in conduction, the electron is at a low energy state. Therefore, the semiconductors pretend like an insulator.

**47. Which of the following is true regarding insulators?**

- a) The valence band is partially filled with electrons
- b) The conduction band is partially filled with electrons
- c) The conduction band is filled with electrons and valence band empty
- d) The conduction band is empty and valence band is filled with electrons

Answer: a

Explanation: In insulators, the conduction band is empty and the valence band is filled with electrons. The other options do not correspond to the concept of insulators, but rather conductors and semiconductors.

**48. Crystalline solids are which of the following?**

- a) Anisotropic
- b) Isotropic
- c) Amorphous
- d) Unipotential

Answer: a

Explanation: Crystalline solids are anisotropic as they show different physical properties in a different direction. Therefore, they are neither isotropic, amorphous, nor unit potential in nature.

**49. Which of the following is an amorphous solid?**

- a) Glass
- b) Diamond
- c) Salt
- d) Sugar

Answer: a

Explanation: Glass is an amorphous solid. It is a non-crystalline solid in which the atoms and molecules are not organized in a definite lattice pattern. The other options are crystalline.

**50. At which temperature, a pure semiconductor behaves slightly as a conductor?**

- a) Low temperature
- b) Room temperature
- c) High temperature
- d) Supercritical temperature

Answer: c

Explanation: A pure semiconductor behaves slightly as a conductor at high temperatures. Their resistivity decreases as temperature increases. Therefore, at high temperatures, semiconductors slightly act as a conductor.

**51. How many junction/s do a diode consist?**

- a) 0
- b) 1
- c) 2
- d) 3

Answer: b

Explanation: Diode is a one junction semiconductor device which has one cathode and anode. The junction is of p-n type.

**52. If the positive terminal of the battery is connected to the anode of the diode, then it is known as**

- a) Forward biased
- b) Reverse biased
- c) Equilibrium
- d) Schottky barrier

Answer: a

Explanation: When a positive terminal is connected to the anode, the diode is forward biased which lets the flow of the current in the circuit.

**53. During reverse bias, a small current develops known as**

- a) Forward current
- b) Reverse current
- c) Reverse saturation current
- d) Active current

Answer: c

Explanation: When the diode is reverse biased, a small current flows between the p-n junction which the order of the Pico ampere. This current is known as reverse saturation current.

**54. If the voltage of the potential barrier is  $V_0$ . A voltage  $V$  is applied to the input, at what moment will the barrier disappear?**

- a)  $V < V_0$
- b)  $V = V_0$
- c)  $V > V_0$
- d)  $V \ll V_0$

Answer: b

Explanation: When the voltage will be same that of the potential barrier, the potential barrier disappears resulting in flow of current.

**55. During the reverse biased of the diode, the back resistance decrease with the increase of the temperature. Is it true or false?**

- a) True
- b) False

Answer: a

Explanation: Due to the increase in the reverse saturation current due to the increase in the temperature, the back resistance decrease with the increasing temperature.

**56. What is the maximum electric field when  $V_{bi}=2V$  ,  $V_R=5V$  and width of the semiconductor is 7cm?**

- a) -100V/m
- b) -200V/m
- c) 100V/m
- d) 200V/m

Answer: b

Explanation:  $E_{max} = -2(V_{bi} + V_R) / W$   
 $= -2(2+5) / (7 \times 10^{-2})$   
 $= -200V/m.$

**57. When the diode is reverse biased with a voltage of 6V and  $V_{bi}=0.63V$ . Calculate the total potential.**

- a) 6V
- b) 6.63V
- c) 5.27V
- d) 0.63V

Answer: b

Explanation:  $V_t = V_{bi} + V_R$   
 $= 0.63 + 6$   
 $= 6.63V.$



**58. It is possible to measure the voltage across the potential barrier through a voltmeter?**

- a) True
- b) False

Answer: b

Explanation: The contacts of the voltmeter have some resistance which will not accurately measure the voltage across the potential barrier. Thus, it is not possible to measure the voltage across the potential barrier.



**60. How many PN junctions is/are present in a bipolar junction transistor?**

- a) 0
- b) 1
- c) 2
- d) 3

Answer: c

Explanation: A bipolar junction transistor (BJT) contains 2 PN junctions. If the transistor is NPN type then it contains a P-type semiconductor sandwiched between two N-type semiconductor. If the transistor is PNP type then it contains a N-type semiconductor sandwiched between two P-type semiconductor. In both the cases there are two PN junctions.

**61. What are the majority charge carriers**

- a) Electrons
- b) Holes
- c) Negative Ions
- d) Positive Ions

Answer: b

Explanation: Holes are the majority charge carriers in P-type semiconductors. These holes are actually electron vacancies that contain positive charge. The holes are responsible for the conduction in p-type semiconductors.

**62. What are present at the potential barrier of a PN junction when no external voltage is applied?**

- a) Electrons
- b) Holes
- c) Positive Ions
- d) Positive and Negative Ions

Answer: d

Explanation: Positive and Negative Ions are present at the potential barrier of a PN junction when no external voltage is applied. These Ions are immobile and are accumulated which does not allow the electrons and holes to cross the junction until an external voltage is applied.

**63. Which is an example of Schottky diode?**

- a) MSP430G2ET
- b) CMCP793V-500
- c) SLB700A/06VA
- d) MBR5H100MFST1G

Answer: d

Explanation: MBR5H100MFST1G is an example of Schottky diode. Schottky diodes are most common PN junction diodes used in analog electronics. It is a simple diode that contain P and N junction but has a fast switching action and a low forward voltage drop.

**64. Ions do not move in a PN junction.**

- a) True
- b) False

Answer: a

Explanation: Ions does not move in a PN junction. They are immobile. They are created due to the absence of charge carriers at a position. If an electron moves from one place to another, then it leaves behind a vacancy which is positively charged. This vacancy is called Positive Ion.

**65. When the p-type semiconductor is connected to positive terminal and n-type to negative terminal of a PN junction diode then the diode is said to be reverse biased.**

- a) True
- b) False

Answer: b

Explanation: When the p-type semiconductor is connected to positive terminal and n-type to negative terminal of a PN junction diode then the diode is said to be forward biased. In forward biased configuration the holes start to move towards N type semiconductor and the electrons towards P type semiconductor, this leads to flow of current in the diode.

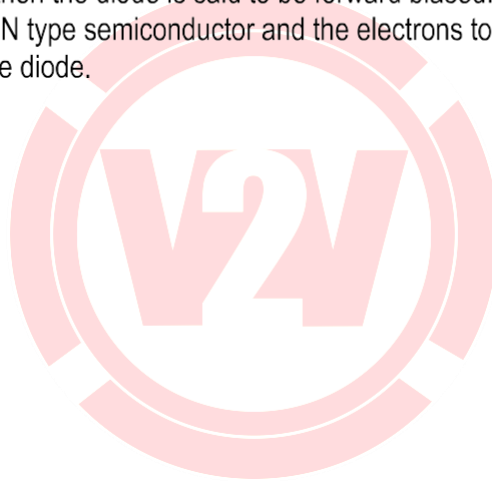

**66. What is the minimum voltage required to make the PN junction of a real silicon transistor in forward biased?**

- a) 0.7 volts
- b) 0.8 volts
- c) 0.9 volts
- d) 0.3 volts

Answer: a

Explanation: 0.7 volts is the minimum voltage required to make the PN junction of a real silicon transistor in forward biased. This 0.7 volt potential difference makes the PN junction between base and emitter terminal in forward biased.

**67. Which is an example of PN junction diode?**

- a) Light Emitting Diode
- b) Light dependent resistor
- c) Photo Voltaic cell
- d) Capacitor

Answer: a

Explanation: Light Emitting Diode (LED) is an example of PN junction diode. A layer of Phosphor is added at the junction who is responsible for the glow. Phosphor is a substance that exhibits the phenomenon of luminescence.

**68. What are the parameters over which a diode characteristics curve is made?**

- a) Current and time
- b) Voltage and time
- c) Current and frequency
- d) Voltage and current

Answer: d

Explanation: Voltage and current are the parameters considering which a diode characteristics curve is made. It is voltage versus current graph in which Current is denoted on Y-axis and voltage is denoted on (X-axis).

**69. What are the majority charge carriers in N-type semiconductors?**

- a) Electrons
- b) Holes
- c) Negative Ions
- d) Positive Ions

Answer: a

Explanation: Electrons are the majority charge carriers in N-type semiconductors. When a potential difference is created across the terminals of semiconductor, the electrons starts to move, these free electrons are responsible for the conduction in N-type semiconductors.

**70. What happens when a trivalent semiconductor is doped with a pure semiconductor?**

- a) N-Type extrinsic semiconductor is formed
- b) P-Type extrinsic semiconductor is formed
- c) PN junction is formed
- d) NP junction is formed

Answer: b

Explanation: P-Type extrinsic semiconductor is formed when a trivalent semiconductor is doped with a pure semiconductor. Holes are the majority charge carriers in P-type semiconductor, whereas electrons are majority charge carriers in N type semiconductors.



**71. What happens when a pentavalent semiconductor is doped with a pure semiconductor?**

- a) N-Type extrinsic semiconductor is formed
- b) P-Type extrinsic semiconductor is formed
- c) PN junction is formed
- d) NP junction is formed

Answer: a

Explanation: N-Type extrinsic semiconductor is formed when a pentavalent semiconductor is doped with a pure semiconductor. Electrons are the majority charge carriers in N-type semiconductor, whereas holes are majority charge carriers in P type semiconductors.

**72. Which impurity should be added to pure semiconductor to make a P-type semiconductor?**

- a) Arsenic
- b) Phosphorus
- c) Boron
- d) Antimony

Answer: c

Explanation: Boron should be added to pure semiconductor to make a P-type semiconductor. P-Type extrinsic semiconductor is formed when a trivalent semiconductor is doped with a pure semiconductor. Boron is a trivalent compound whereas all others are pentavalent compound.

**73. Which impurity should be added to pure semiconductor to make an N-type semiconductor?**

- a) Gallium
- b) Phosphorus
- c) Indium
- d) Aluminum

Answer: b

Explanation: Aluminum should be added to pure semiconductor to make a N-type semiconductor. N-Type extrinsic semiconductor is formed when a pentavalent semiconductor is doped with a pure semiconductor. Phosphorus is a pentavalent compound whereas all others are trivalent compound.

**74. PN junction can be made by physically joining P type and N type semiconductor.**

- a) True
- b) False

Answer: b

Explanation: PN junction cannot be made by physically joining P type and N type semiconductor. Even when P type and N type materials are held firmly then also huge microscopic gaps are present between both the semiconductors which does not allow holes and electrons to pass through it.

**75. Which of the following is operated in forward bias?**

- a) LED
- b) Zener diode
- c) Photodiode
- d) Solar cell

Answer: a

Explanation: A light-emitting diode (LED) converts electric energy into light energy. A LED is a heavily doped p-n junction which under forward bias emits spontaneous radiation. The semiconductor used for the fabrication of visible LEDs must at least have a bandgap of 1.8 eV.

**76. Which of the following converts light energy to electric current?**

- a) LED
- b) Zener diode
- c) Photodiode
- d) Solar cell

Answer: c

Explanation: A photodiode is a semiconductor device, which converts light energy to electric energy. It is a special type p-n junction diode fabricated with a transparent window to allow light to fall on the diode. Photodiodes are operated in reverse bias.

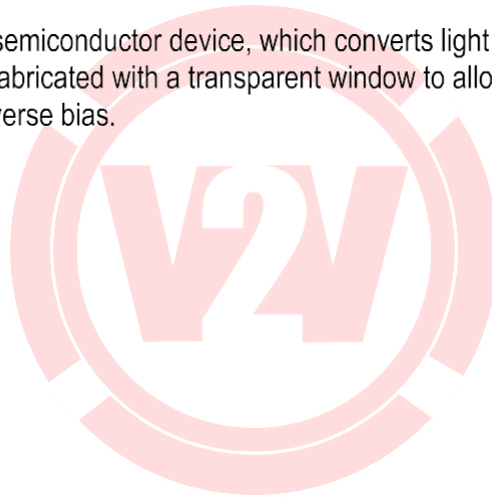

**77. Identify the one on which no external**

- a) Zener diode
- b) Solar cell
- c) Photodiode
- d) Light-emitting diode

Answer: b

Explanation: Solar cells convert solar energy into electric energy. A solar cell is a p-n junction that generates emf when solar radiation falls on the p-n junction. It works on the same principle as the photodiode, except that no external bias is applied and the junction area is kept large.

**78. What does the conductivity of metals depend upon?**

- a) The nature of the material
- b) Number of free electrons
- c) Resistance of the metal
- d) Number of electrons

Answer: b

Explanation: The conducting property of a solid is not a function of a total number of electrons in the metal, but it is due to the number of valance electrons called free electrons.

**78. The free electrons collide with the lattice elastically.**

- a) True
- b) False

Answer: a

Explanation: The free electrons move randomly in all directions. The free electrons collide with each other and also with the lattice Elastically, without loss in energy.

**79. What happens to the free electrons when an electric field is applied?**

- a) They move randomly and collide with each other
- b) They move in the direction of the field
- c) They remain stable
- d) They move in the direction opposite to that of the field

Answer: d

Explanation: The free electrons move in the direction opposite to that of field direction. Since they are assumed to be a perfect gas as they obey classical kinetic theory of gases and the electron velocities in the metal obey the Maxwell-Boltzmann statistics.

advertisement

**80. Thermal conductivity is due to photons.**

- a) True
- b) False

Answer: a

**81. Which of the following theories cannot be explained by classical**

- a) Electron theory
- b) Lorentz theory
- c) Photo-electric effect
- d) Classical free electron theory

Answer: c

Explanation: Classical theory states that all free electrons will absorb energy. This theory cannot explain the photo electric effect.

**82. Which of the following theories can be adopted to rectify the drawbacks of classical**

- a) Compton theory
- b) Quantum theory
- c) Band theory
- d) Electron theory

Answer: b

Explanation: In classical theory, the properties of metals, such as electrical and thermal conductivities are well explained on the assumption that the electrons in the metal freely moves like the particles of a gas. Hence it can be used to rectify the drawbacks of classical theory.

**83. What is the level that acts as a reference which separated the vacant and filled states at 0K?**

- a) Excited level
- b) Ground level
- c) Valance orbit
- d) Fermi energy level

Answer: d

Explanation: Fermi energy level is the maximum energy level up to which the electrons can be filled at 0K. Thus it acts as reference level which separated the vacant and filled states at 0K.

**84. A uniform silver wire has a resistivity of  $1.54 \times 10^{-18}$  ohm/m at room temperature. For an electric field along the wire of 1 volt/cm. Compute the mobility, assuming that there are  $5.8 \times 10^{28}$  conduction electrons/m<sup>3</sup>.**

- a) 1.54 m<sup>2</sup>/Vs
- b) 6.9973m<sup>2</sup>/Vs
- c)  $6.9973 \times 10^{-3}$  m<sup>2</sup>/Vs
- d) 0.69973m/s

Answer: c

Explanation: Mobility of the electrons =  $1/\rho e$   
Mobility =  $6.9973 \times 10^{-3}$  m<sup>2</sup>/Vs.



85. Calculate the drift velocity of the free electrons with mobility of  $3.5 \times 10^{-3} \text{ m}^2/\text{Vs}$  electric field strength of  $0.5 \text{ V/m}$ .

- a)  $3.5 \text{ m/s}$
- b)  $1.75 \times 10^3 \text{ m/s}$
- c)  $11.5 \text{ m/s}$
- d)  $1.75 \times 10^{-3} \text{ m/s}$

Answer: d

Explanation: Drift velocity =  $\mu E$

Drift velocity =  $3.5 \times 10^{-3} \times 0.5 = 1.75 \times 10^{-3} \text{ m/s}$ .

86. The Fermi temperature of a metal is  $24600 \text{ K}$ . Calculate the Fermi velocity.

- a)  $0.5 \text{ m/s}$
- b)  $1.38 \text{ m/s}$
- c)  $0.8633 \times 10^6 \text{ m/s}$
- d)  $9.11 \times 10^{-3} \text{ m/s}$

Answer: c

Explanation:  $E_F = K_B T_F$   $1/2$

$v_F = \sqrt{2 \times K_B \times T_F m}$

$v_F = 0.8633 \times 10^6 \text{ m/s}$ .



**87. Insulation breakdown may occur at \_\_\_\_\_**

- a) High temperature
- b) Low temperature
- c) At any temperature
- d) Depends on pressure

Answer: a

Explanation: At high temperatures, electrons of insulators get excited and then the electrons can overcome the large energy band gaps between valence and conduction bands. So a large number of electrons travel to the conduction band and they act as conductor i.e. insulation breakdown occurs.

**88. Superconductors have \_\_\_\_\_**

- a) Almost zero resistivity
- b) Very high resistivity
- c) Temperature-dependent resistivity
- d) Moderate value of resistivity

Answer: a

Explanation: Superconductors are those which carry current with almost zero resistivity at a very low temperature (example: Lead at -272-degree centigrade). So, they have a very huge amount of current flow through them.

**89. Current carrier in conductors is \_\_\_\_\_**

- a) Electron
- b) Proton
- c) Neutron
- d) Positron

Answer: a

Explanation: Conductors have lots of free electrons that can carry electricity if the potential difference is applied across them. Protons are positively charged particle and Neutron are electrically neutral. They don't carry electricity in conductors.

**90. Which group among the following is insulator?**

- a) Silver, copper, gold
- b) Paper, glass, cotton
- c) The human body, wood, iron
- d) Glass, copper, paper

Answer: b

Explanation: Glass, paper, and cotton are good quality insulators. The rest options contain one or more conducting materials. Silver is the best conductor material available in nature. But it is costly, so it can't be used in the electricity distribution system.

**91. The band gap between the valence band and conduction band is the measure of \_\_\_\_\_**

- a) The conductivity of the material

- b) The resistivity of the material
- c) Charge density
- d) Ease of ionization

Answer: a

Explanation: The more the band gap between the valence band and conduction band, the worse is the conductivity of the material. For conductors, there are overlapping bands. So, conductors can carry electricity. But there is a huge energy gap in the case of insulators. So, they don't carry electricity at all.  
advertisement

**92. A static electricity experiment can be performed properly in any season. The statement is**

- a) True
- b) False

Answer: b

Explanation: In the rainy season, the air becomes humid. Humid air is a good conductor compared to dry air and so they carry the static charges of a body. So, a body cannot hold its charge for long in humid season.

**barrier is  $V_0$ . A voltage  $V$  is applied to the input, at what moment**

**93. The rubber used in the wheels of aero-plane is \_\_\_\_\_**

- a) Perfect insulator
- b) Slightly conducting
- c) Can be an insulator or conducting
- d) Semiconductor

Answer: b

Explanation: Due to high friction during takeoff, a huge amount of charge is produced on the rubber of the wheel of a plane. This charge must be sent to the ground. So, the rubber used is slightly conducting, else the huge charge produced may produce a spark and can cause an accident.

**94. How many junction/s do a diode consist?**

- a) 0
- b) 1
- c) 2
- d) 3

Answer: C

Explanation: diode consist of 2 junction forward n reverse

**95. If the positive terminal of the battery is connected to the anode of the diode, then it is known as**

- a) Forward biased
- b) Reverse biased
- c) Equilibrium
- d) Schottky barrier

Answer: a

Explanation: If the positive terminal of the battery is connected to the anode of the diode, then it is known  
Explanation: Reverse saturation current flow during reverse bias, a small current develops

**98. When the diode is reverse biased with a voltage of 6V and  $V_{bi}=0.63V$ . Calculate the total potential.**

- a) 6V
- b) 6.63V
- c) 5.27V
- d) 0.63V

Answer: b

Explanation:  $V_t = V_{bi} + V_R$   
 $= 0.63 + 6$   
 $= 6V$ .

**99. It is possible to measure the voltage across the potential barrier through a voltmeter?**

- a) True
- b) False

Answer: b

Explanation: The contacts of the voltmeter have some resistance which will not accurately measure the voltage across the potential barrier. Thus, it is not possible to measure the voltage across the potential barrier

**100. Zener diodes are also known as**

- a) Voltage regulators
- b) Forward bias diode
- c) Breakdown diode
- d) None of the mentioned

Answer: c

Explanation: Zener diodes are used as voltage regulators but they aren't called voltage regulators. They are called breakdown diodes since they operate in breakdown region.

## UNIT-2

1. Which of the following isn't a type of rectifier?

- a) Precision Half-wave Rectifier
- b) Bridge Rectifier
- c) Peak Rectifier
- d) None of the mentioned

Answer: d

Explanation: All of the mentioned are different types of a rectifier.

2. For a half wave or full wave rectifier the Peak Inverse Voltage of the rectifier is always

- a) Greater than the input voltage
- b) Smaller than the input voltage
- c) Equal to the input voltage
- d) Greater than the input voltage for full wave rectifier and smaller for the half wave rectifier

Answer: b

Explanation: The peak input voltage is smaller than the input voltage due to the presence of diode(s). A single diode reduces the output voltage by approximately 0.7V.

3. For a half-wave rectifier having diode voltage  $V_D$  and supply input of  $V_I$ , the diode conducts for  $\pi - 2\theta$ , where  $\theta$  is given by

- a)  $\tan^{-1} V_D/V_I$
- b)  $\tan^{-1} V_D/V_I - V_I$
- c)  $\sin^{-1} V_D/V_I$
- d)  $\sin^{-1} V_D/V_I - V_I$

Answer: c

Explanation: The diode doesn't conduct when  $V_D \geq V_I$ . Hence  $\theta = \sin^{-1}(D/V_I)$ .

4. Bridge rectifier is an alternative for

- a) Full wave rectifier
- b) Peak rectifier
- c) Half wave rectifier
- d) None of the mentioned

Answer: a

Explanation: Bridge rectifier is a better alternative for a full wave

5. Which of the following is true for a bridge rectifier?

- a) The peak inverse voltage or PIV for the bridge rectifier is lower when compared to an identical tapped rectifier
- b) The output voltage for the center tapped rectifier is lower than the identical bridge rectifier
- c) A transistor of higher number of coil is required for center tapped rectifier than the identical bridge rectifier
- d) All of the mentioned

Answer: d

Explanation: All of the given statements are true for a bridge rectifier.

6. The diode rectifier works well enough if the supply voltage is much than greater than 0.7V. voltage (of few hundreds of millivolt) input which of the following can be used?

- a) Superdiode
- b) Peak rectifier
- c) Precision rectifier
- d) None of the mentioned

Answer: a

Explanation: For the supply voltages less than 0.7V super diodes are used.

7. A simple diode rectifier has 'ripples' in the output wave which makes it unsuitable as a DC source. To overcome this one can use

- a) A capacitor in series with a the load resistance
- b) A capacitor in parallel to the load resistance
- c) Both of the mentioned situations will work
- d) None of the mentioned situations will work

Answer: b

Explanation: A capacitor is parallel with a resistor can only makes ripples go away. Series connection will become equal to an open circuit once the capacitor is fully charged.

8. Consider a peak rectifier fed by a 60-Hz sinusoid having a peak value  $V_p = 100$  V. Let the load resistance  $R = 10$  k $\Omega$ . Calculate the fraction of the cycle during which the diode is conducting

- a) 1.06 %
- b) 2.12 %
- c) 3.18%
- d) 4.24%

Answer: c

Explanation:  $w \Delta t \sim \sqrt{(2V_r/V_p)}$

$$\Theta = \sqrt{(2 \times 2/100)}$$

$$\Theta = 0.2 \text{ rad or } 3.18\% \text{ of the cycle}$$

9. DC average current of a bridge full wave rectifier (where  $I_m$  is the maximum peak current of input).

- a)  $2I_m$
- b)  $I_m$
- c)  $I_m/2$
- d)  $1.414I_m$

Answer: b

Explanation: Average DC current of half wave rectifier is  $I_m$ . Since output of half wave rectifier contains only one half of the input. The average value is the half of the area of one half cycle of sine wave with peak  $I_m$ . This is equal to  $I_m$ .

10. DC power output of bridge full wave rectifier is equal to ( $I_m$  is the peak current and  $R_L$  is the load resistance).

- a)  $2 I_m^2 R_L$
- b)  $4 I_m^2 R_L$
- c)  $I_m^2 R_L$
- d)  $I_m^2 R_L/2$

Answer: b

Explanation: DC output power is the power output of the rectifier. We know  $V_{DC}$  for a bridge rectifier is  $2V_m$  and  $I_{DC}$  for a bridge rectifier is  $2I_m$ . We also know  $V_{DC}=I_{DC}/R_L$ . Hence output power is  $4I_m^2 R_L$ .

11. Ripple factor of bridge full wave rectifier is?

- a) 1.414
- b) 1.212
- c) 0.482
- d) 1.321

Answer: c

Explanation: Ripple factor of a rectifier measures the ripples or AC content in the output. It's obtained by dividing AC rms output with DC output. For full wave bridge rectifier it is 0.482.

12. If input frequency is 50Hz then ripple frequency of bridge full wave rectifier will be equal to \_\_\_\_\_

- a) 200Hz
- b) 50Hz
- c) 45Hz
- d) 100Hz

Answer: d

Explanation: Since in the output of bridge rectifier one half cycle is repeated, the frequency will be twice as that of input frequency. So,  $f=100\text{Hz}$ .

13. Transformer utilization factor of bridge full wave rectifier \_\_\_\_\_

- a) 0.623
- b) 0.812
- c) 0.693
- d) 0.825

Answer: b

Explanation: Transformer utilization factor is the ratio of AC power delivered to load to the DC power rating. This factor indicates effectiveness of transformer usage by rectifier. For bridge full wave rectifier it's equal to 0.693.

14. If peak voltage on a bridge full wave rectifier circuit is 5V and diode cut in voltage is 0.7, then the peak inverse voltage on diode will be \_\_\_\_\_

- a) 4.3V
- b) 9.3V
- c) 8.6V
- d) 3.6V

Answer: d

Explanation: PIV is the maximum reverse bias voltage that can be appeared across a diode in the circuit. If PIV rating of diode is less than this value breakdown of diode may occur. Therefore, PIV rating of diode should be greater than PIV in the circuit, For bridge rectifier PIV is  $V_m - V_D = 5 - 1.4 = 3.6$ .

15. Efficiency of bridge full wave rectifier is \_\_\_\_\_

- a) 81.2%
- b) 50%
- c) 40.6%
- d) 45.33%

Answer: a

Explanation: It's obtained by taking ratio of DC power output to maximum AC power delivered to load. Efficiency of a rectifier is the effectiveness of rectifier to convert AC to DC. It's usually expressed in percentage. For bridge full wave rectifier, it's 81.2%.

16. In a bridge full wave rectifier, the input sine wave The average output voltage is \_\_\_\_\_

- a) 22.73V
- b) 16.93V
- c) 25.47V
- d) 33.23V

Answer: c

Explanation: The equation of sine wave is in the form  $E_m \sin \omega t$ . Therefore,  $E_m = 40$ . Hence output voltage is  $2E_m = 80V$ .



17. Number of diodes used in a full wave bridge rectifier is \_\_\_\_\_

- a) 1
- b) 2
- c) 3
- d) 4

Answer: d

Explanation: The model of a bridge rectifier is same as Wein Bridge. It needs 4 resistors. Bridge rectifier needs 4 diodes while centre tap configuration requires only one.

18. In a bridge full wave rectifier, the input sine wave is  $250\sin 100t$ . The output ripple frequency will be \_\_\_\_\_

- a) 50Hz
- b) 200Hz
- c) 100Hz
- d) 25Hz

Answer: c

Explanation: The equation of sine wave is in the form of  $E_m \sin \omega t$ . So,  $\omega = 100$  and frequency  $(f) = \omega / 2 = 50\text{Hz}$ . Since output of bridge rectifier have double the frequency of input,  $f = 100\text{Hz}$ .

19. Efficiency of a centre tapped full wave rectifier is \_\_\_\_\_

- a) 50%
- b) 46%
- c) 70%
- d) 81.2%

Answer: d

Explanation: Efficiency of a rectifier is the effectiveness to convert AC to DC. It's obtained by taking ratio of DC power output to maximum AC power delivered to load. It's usually expressed in percentage. For centre tapped full wave rectifier, it's 81.2%.

20. A full wave rectifier supplies a load of  $1\text{K}\Omega$ . The AC voltage applied to diodes is 220V (rms). If diode resistance is neglected, what is the ripple voltage?

- a) 0.562V
- b) 0.785V
- c) 0.954V
- d) 0.344V

Answer: c

Explanation: The ripple voltage is  $(V_r)_{\text{RMS}} = \gamma V_{\text{DC}} / 100$ .

$V_{\text{DC}} = 0.636 * V_{\text{RMS}} * \sqrt{2} = 0.636 * 220 * \sqrt{2} = 198\text{V}$  and ripple factor  $\gamma$  for full wave rectifier is 0.482.

Hence,  $(V_r)_{\text{RMS}} = 0.482 * 198 / 100 = 0.954\text{V}$ .

21. A full wave rectifier delivers 50W to a load of  $200\Omega$ . If the ripple factor is 2%, calculate the AC ripple

across the load.

- a) 2V
- b) 5V
- c) 4V
- d) 1V

Answer: a

Explanation: We know that,  $P_{DC} = V_{DC} I_{DC}$ . So,  $V_{DC} = (P_{DC} / I_{DC})^{1/2} = (10000 / 100)^{1/2} = 100V$ .

Here,  $V_{AC} = 0.02$

$V_{AC} / V_{DC} = V_{AC} / 100$ . So,  $V_{AC} = 0.02 * 100 = 2V$ .

22. If input frequency is 50Hz for a full wave rectifier, the ripple frequency of it would be \_\_\_\_\_

- a) 100Hz
- b) 50Hz
- c) 25Hz
- d) 500Hz

Answer: a

Explanation: In the output of the centre tapped rectifier, one of the half cycle is repeated. The frequency will be twice as that of input frequency. So, it's 100Hz.

23. If the peak voltage on a centre tapped full wave rectifier circuit is 5V and diode cut in voltage is 0.7. The peak inverse voltage on diode is \_\_\_\_\_

- a) 4.3V
- b) 9.3V
- c) 5.7V
- d) 10.7V

Answer: b

Explanation: PIV is the maximum reverse bias voltage that can be appeared across a diode in the given circuit, if PIV rating is less than this value of breakdown of diode will occur. For a rectifier,  $PIV = 2V_m - V_d = 10 - 0.7 = 9.3V$ .

24. In a shunt capacitor filter, the mechanism that helps the removal of ripples is \_\_\_\_\_

- a) The current passing through the capacitor
- b) The property of capacitor to store electrical energy
- c) The voltage variations produced by shunting the capacitor
- d) Uniform charge flow through the rectifier

Answer: b

Explanation: Filtering is frequently done by shunting the load with capacitor. It depends on the fact that a capacitor stores energy when conducting and delivers energy during non conduction. Throughout this process, the ripples are eliminated.

25. The cut-in point of a capacitor filter is \_\_\_\_\_

- a) The instant at which the conduction starts
- b) The instant at which the conduction stops
- c) The time after which the output is not filtered
- d) The time during which the output is perfectly filtered

Answer: a

Explanation: The capacitor charges when the diode is in ON state and discharges during the OFF state of the diode. The instant at which the conduction starts is called cut-in point. The instant at which the conduction stops is called cut-out point.

The rectifier current is a short duration pulses which cause the diode to act as a \_\_\_\_\_

- a) Voltage regulator
- b) Mixer
- c) Switch
- d) Oscillator

Answer: c

Explanation: The diode permits charge to flow in capacitor when the transformer voltage exceeds the capacitor voltage. It disconnects the power source when the transformer voltage falls below that of a capacitor.

27. A half wave rectifier, operated from a 50Hz supply uses a 1000 $\mu$ F capacitance connected in parallel to the load of rectifier. What will be the minimum value of load resistance that can be connected across the capacitor if the ripple% not exceeds 5?

- a) 114.87 $\Omega$
- b) 167.98 $\Omega$
- c) 115.47 $\Omega$
- d) 451.35 $\Omega$

Answer: c

Explanation: For a half wave filter,

$$\frac{V}{\sqrt{3}} = \frac{1}{2} \sqrt{3} f C R L = \frac{1}{2} \sqrt{3} * 50 * 10^{-3} * R L$$

$$R L = \frac{103}{5 \sqrt{3}} = 115.47 \Omega.$$

28. A  $100\mu\text{F}$  capacitor when used as a filter has 15V ac across it with a load resistor of  $2.5\text{K}\Omega$ . If the filter is the full wave and supply frequency is 50Hz, what is the percentage of ripple frequency in the output?

- a) 2.456%
- b) 1.154%
- c) 3.785%
- d) 3.675%

Answer: b

Explanation: For a full wave rectifier,  $\%r = \frac{1}{4\sqrt{3}} f_{CRL}$   
 $= \frac{1}{4\sqrt{3}} * 50 * 10^{-3} * 2.5$   
 $= 0.01154$ . So, ripple is 1.154%.

29. A full wave rectifier uses a capacitor filter with  $500\mu\text{F}$  capacitor and provides a at 8% ripple. Calculate the dc voltage.

- a) 15.56V
- b) 20.43V
- c) 11.98V
- d) 14.43V

Answer: d

Explanation: The ripple factor  $\%r = \frac{1}{4\sqrt{3}} f_{CVDC}$   
 $V_{DC} = \frac{200 * 10^{-3}}{4\sqrt{3}} * 50 * 500 * 8$   
 $= 14.43$ .

30. The charge (q) lost by the capacitor during the discharge time for shunt capacitor filter.

- a)  $I_{DC} * T$
- b)  $I_{DC} / T$
- c)  $I_{DC} * 2T$
- d)  $I_{DC} / 2T$

Answer: a

31. Which of the following are true about capacitor filter?

- a) It is also called as capacitor output filter
- b) It is electrolytic
- c) It is connected in parallel to load
- d) It helps in storing the magnetic energy

Answer: b

Explanation: The rectifier may be full wave or half wave. The capacitors are usually electrolytic even though they are large in size.

32. The rms ripple voltage ( $V_{rms}$ ) of a shunt filter is \_\_\_\_\_

- a)  $IDC/2\sqrt{3}$
- b)  $IDC2\sqrt{3}$
- c)  $IDC/\sqrt{3}$
- d)  $IDC\sqrt{3}$

Answer: a

Explanation: The ripple waveform will be triangular in nature. The rms value of this wave is independent of slopes or lengths of straight lines. It depends only on the peak value.

33. A shunt capacitor of value  $500\mu F$  fed rectifier circuit. The dc voltage is 14.43V. The dc current flowing is 200mA. It is operating at a frequency of 50Hz. What will be the value of peak rectified voltage?

- a) 18.67V
- b) 16.43V
- c) 15.98V
- d) 11.43V

Answer: b

Explanation: We know,  $V_m = V_{dc} + I_{dc}/4fC$   
 $= 14.43 + \{200 / (200 \times 500)\} \times 10^3$   
 $= 14.43 + 2 = 16.43V.$

34. What is the effect of an inductor filter on a multi frequency signal?

- a) Dampens the AC signal
- b) Dampens the DC signal
- c) To reduce ripples
- d) To change the current

Answer: a

Explanation: Presence of inductor usually dampens the AC signal. Due to self induction EMF or changes in the current.

35. The ripple factor ( $\gamma$ ) of inductor filter is \_\_\_\_\_

- a)  $\gamma = RZ/3\sqrt{2}\omega L$
- b)  $\gamma = RZ/3\sqrt{2}\omega L$
- c)  $\gamma = RZ3\sqrt{2}/\omega L$
- d)  $\gamma = RZ3/\sqrt{2}\omega L$

Answer: b

Explanation: Ripple factor will decrease when L is increased and RL. Inductor has a higher dc resistance. depends on property of opposing the change of direction of current.

36. The inductor filter gives a smooth output because \_\_\_\_\_

- a) It offers infinite resistance to ac components
- b) It offers infinite resistance to dc components
- c) Pulsating dc signal is allowed
- d) The ac signal is amplified

Answer: a

Explanation: The inductor does not allow the ac components to pass through the filter. The main purpose of using an inductor filter is to avoid the ripples. By using this property, the inductor offers an infinite resistance to ac components and gives a smooth output.

37. A full wave rectifier with a load resistance of  $5K\Omega$  uses an inductor filter of 15henry. The peak value of applied voltage is 250V and the frequency is 50 cycles per second. Calculate the dc load current.

- a) 0.7mA
- b) 17mA
- c) 10.6mA
- d) 20mA

Answer: c

Explanation: For a rectifier with an inductor filter,  
 $V_{DC} = 2V_m/\pi$ ,  $I_{dc} = V_{DC}/R_L = 2V_m/RL\pi$   
 $I_{DC} = 2*250/(3.14*15*10^3) = 10.6mA$ .

38. The output of a rectifier is pulsating because \_\_\_\_\_

- a) It has a pulse variations
- b) It gives a dc output
- c) It contains both dc and ac components
- d) It gives only ac components

Answer: c

Explanation: For any electronic devices, a steady dc output is required. The filter is used for this purpose. The ac components are removed by using a filter.

39. A dc voltage of 380V with a peak ripple voltage not exceeding 7V is required to supply a  $500\Omega$  load. Find out the inductance required.

- a) 10.8henry
- b) 30.7henry
- c) 28.8henry
- d) 15.4henry

Answer: c

Explanation: Given the ripple voltage is 7V. So,  $7 = 1.414V_{RMS}$   
 $V_{RMS}/V_{DC} = 4.95/380 = 0.0130$ .  $\frac{1}{3}\sqrt{2}(RL/L\omega)$   
So,  $L = 28.8\text{henry}$ .

40. The inductor filter should be used when  $R_L$  is consistently small because \_\_\_\_\_

- a) Effective filtering takes place when load current is high
- b) Effective filtering takes place when load current is low
- c) Current lags behind voltage
- d) Current leads voltage

Answer: a

Explanation: When  $R_L$  is infinite, the ripple factor is 0.471. This value is close to that of a rectifier. So, the resistance should be small.

41. The output voltage  $V_{DC}$  for a rectifier with inductor filter is given by \_\_\_\_\_

- a)  $(2V_m/\pi) - I_{DC}R$
- b)  $(2V_m/\pi) + I_{DC}R$
- c)  $(2V_m\pi) - I_{DC}R$
- d)  $(2V_m\pi) + I_{DC}R$

Answer: a

Explanation: The inductor with high resistance can cause poor voltage regulation. The choke resistance, the resistance of half of transformer secondary is not negligible.

42. What causes to decrease the sudden rise in the current for a rectifier?

- a) the electrical energy
- b) The ripple factor
- c) The magnetic energy
- d) Infinite resistance

Answer: c

Explanation: When the output current of a rectifier increases above a certain value, magnetic energy is stored in the inductor. This energy tends to decrease the sudden rise in the current. This also helps to prevent the current to fall down too much.

43. A full wave rectifier with a load resistance of  $5K\Omega$  uses an inductor filter of 15henry. The peak value of applied voltage is 250V and the frequency is 50 cycles per second. Calculate the ripple factor ( $\gamma$ ).

- a) 0.1
- b) 0.6
- c) 0.5
- d) 0.4

Answer: d

Explanation:  $\gamma = I_{AC}/I_{DC}$ ,  $I_{AC} = 2\sqrt{2}V_m/3\pi(R_L^2 + 4\omega^2L^2)^{1/2}$

By putting the values,  $I_{AC} = 4.24\text{Ma}$ .  $V_{DC} = 2V_m/\pi$ ,  $I_{DC} = V_{DC}/R_L = 2V_m/R_L \pi$

$I_{DC} = 2*250/(3.14*15*103) = 10.6\text{mA}$ .  $\gamma = 4.24/10.6 = 0.4$ .

44. An L section filter with  $L=2\text{henry}$  and  $C= 49\mu\text{F}$  is used in the output of a full wave single phase rectifier that is fed from a 40-0-40 V peak transformer. The load current is 0.2A. Calculate the output dc voltage.

- a) 20.76V
- b) 24.46V
- c) 34.78V
- d) 12.67V

Answer: b

Explanation: Given,  $V_L= 40\text{V}$ .

$$V_{DC}=\frac{2}{\pi}V_L=\frac{2}{\pi}40=25.46\text{V}.$$

45. Calculate LC for a full wave rectifier which provides 10V dc at 100mA with a maximum ripple of 2%.

Input ac frequency is 50Hz.

- a)  $40*10^{-6}$
- b)  $10*10^{-6}$
- c)  $30*10^{-6}$
- d)  $90*10^{-6}$

Answer: a

46. The value of inductance at which the current in a choke filter does not fall to zero is \_\_\_\_\_

- a) peak inductance
- b) cut-in inductance
- c) critical inductance
- d) damping inductance

Answer: c

Explanation: When the value of inductance is increased, a value is reached where the diodes supplies current continuously. This value of inductance is called critical inductance.

47. The condition for the regulation curve in a choke filter is \_\_\_\_\_

- a)  $LC \geq RL/3\omega$
- b)  $LC \leq RL/3\omega$
- c)  $L \geq RL/3\omega$
- d)  $LC \geq RL3\omega$

Answer: a

Explanation: IDC should not exceed the negative peak of ac component. So, the regulation curve in direct output voltage against load current for a filter is given the relation  $LC \geq RL/3\omega$ .



48. The ripple factor for an L section filter is\_\_\_\_\_

- a)  $\frac{1}{6}\sqrt{2\omega 2LC}$
- b)  $\frac{1}{6}\sqrt{2\omega 2LC}$
- c)  $\frac{1}{6}\sqrt{3\omega 2LC}$
- d)  $\frac{1}{6}\sqrt{3\omega 2LC}$

Answer: a

Explanation: The ripple factor is the ratio of root mean square (rms) value of ripple voltage to absolute value of dc component. It can also be expressed as the peak to peak value.

49. The output dc voltage of an LC filter is\_\_\_\_\_

- a)  $V_{DC} = 2V_m/\pi + I_{DC}R$
- b)  $V_{DC} = V_m/\pi - I_{DC}R$
- c)  $V_{DC} = 2V_m/\pi - 2I_{DC}R$
- d)  $V_{DC} = 2V_m/\pi - I_{DC}R$

Answer: d

Explanation: The value for  $V_{DC}$  is same as that of inductor filter. If inductor has no dc resistance, then  $V_{DC} = 2V_m/\pi$ . If  $R$  is the series resistance of transformer, then  $V_{DC} = 2V_m/\pi - I_{DC}R$ .

50. The rms value of ripple current for an L section filter is\_\_\_\_\_

- a)  $I_{RMS} = \sqrt{2/3} \cdot X_L \cdot V_{DC}$
- b)  $I_{RMS} = \sqrt{2/3} \cdot X_L \cdot V_{DC}$
- c)  $I_{RMS} = \sqrt{2/3} \cdot X_L \cdot V_{DC}$
- d)  $I_{RMS} = \sqrt{2/3} \cdot X_L \cdot V_{DC}$

Answer: a

Explanation: The ac current through L is determined primarily by  $X_L = 2\omega L$ . It is directly proportional to voltage produced and indirectly proportional to the reactance.

51. What makes the load in a choke filter to bypass harmonic components?

- a) capacitor
- b) inductor
- c) resistor
- d) diodes

Answer: a

Explanation: When the capacitor is shunted across the load, it bypasses the harmonic components. This is because it offers low reactance to ac ripple component. In another hand the inductor offers high impedance to harmonic terms.

52. The ripple to heavy loads by a capacitor is \_\_\_\_\_

- a) high
- b) depends on temperature
- c) low
- d) no ripple at all

Answer: c

Explanation: Ripple factor is inversely proportional to load resistance for a capacitor filter. So, the ripples that are produced are low when the load is high.

53. In a choke I section filter \_\_\_\_\_

- a) the inductor and capacitor are connected across the load
- b) the inductor is connected in series and capacitor is connected across the load
- c) the inductor is connected across and capacitor is connected in series to the load
- d) the inductor and capacitor are connected in series

Answer: b

54. What is the number of capacitors and inductors used in a CLC filter?

- a) 1, 2 respectively
- b) 2, 1 respectively
- c) 1, 1 respectively
- d) 2, 2 respectively

Answer: b

Explanation: A very smooth output can be obtained by a filter consisting of one inductor and two capacitors connected across each other. They are arranged in the form of letter 'pi'. So, these are also called as pi filters.

55. Major part of the filtering is done by the first capacitor in a CLC filter because \_\_\_\_\_

- a) The capacitor offers a very low reactance to the ripple frequency
- b) The capacitor offers a very high reactance to the ripple frequency
- c) The inductor offers a very low reactance to the ripple frequency
- d) The inductor offers a very high reactance to the ripple frequency

Answer: a

56. At  $f=50\text{Hz}$ , the ripple factor of CLC filter is \_\_\_\_\_

- a)  $\frac{1}{5700RL} / (LC1C2)$
- b)  $\frac{1}{5700} / (LC1C2RL)$
- c)  $\frac{1}{5700LC1} / (C2RL)$
- d)  $\frac{1}{5700C1C2} / (LRL)$

Answer: b

57. A single phase full wave rectifier makes use of pi section filter with  $10\mu\text{F}$  capacitors and a choke of 10henry. The secondary voltage is 280V and the load current is 100mA. Determine the dc output voltage when  $f=50\text{Hz}$ .

- a) 345V
- b) 521V
- c) 243V
- d) 346V

Answer: d

Explanation: Given,  $V_{\text{RMS}}=280\text{V}$

So,  $V_m = 1.414*280=396\text{V}$ .

From theory of capacitor filter,  $V_{\text{DC}} = V_m - I_{\text{DC}}/4fC = 396 - 0.1 / (4*50*10*10^{-6}) = 346\text{V}$ .

58. For a given CLC filter, the operating frequency is 50Hz and  $10\mu\text{F}$  capacitors used. The load resistance is  $3460\Omega$  with an inductance of 10henry. Calculate the ripple factor.

- a) 0.165%
- b) 0.142%
- c) 0.178%
- d) 0.321%

Answer: a

Explanation: We have,  $\%r = \frac{1}{LC} \sqrt{\frac{R}{2fC}}$   
 $= \frac{1}{10*100*10^{-12}} \sqrt{\frac{3460}{2*50*10^{-6}}}$   
 $= 0.165\%$ .

59. The inductor is placed in the L section filter because \_\_\_\_\_

- a) It offers zero resistance to DC component
- b) It offers infinite resistance to DC component
- c) It bypasses the DC component
- d) It bypasses the AC component

Answer: a

Explanation: The inductor offers high reactance to ac component and zero resistance to dc component. So, it blocks the ac component which cannot be bypassed by the capacitors.

60. The advantages of a pi-filter is \_\_\_\_\_

- a) low output voltage
- b) low PIV
- c) low ripple factor
- d) high voltage regulation

Answer: c

Explanation: Due to the use of two capacitors with an inductor, an improved filtering action is provided. leads to decrement in ripple factor. A low ripple factor signifies regulated and ripple free DC voltage.

1. Which of the following condition is true for cut-off mode?

- a) The collector current is zero
- b) The collector current is proportional to the base current
- c) The base current is non zero
- d) All of the mentioned

Answer: a

Explanation: The base current as well as the collector current are zero in cut-off mode.

2. Which of the following is true for the cut-off region in an npn transistor?

- a) Potential difference between the emitter and the base is smaller than 0.5V
- b) Potential difference between the emitter and the base is smaller than 0.4V
- c) The collector current increases with the increase in the base current
- d) The collector current is always zero and the base current is always non zero

Answer: b

Explanation: Both collector and emitter current are zero in cut-off region.

3. Which of the following is true for a typical active region of an npn transistor?

- a) The potential difference between the emitter and the collector is less than 0.5 V
- b) The potential difference between the emitter and the collector is less than 0.4 V
- c) The potential difference between the emitter and the collector is less than 0.3 V
- d) The potential difference between the emitter and the collector is less than 0.2 V

Answer: c

4. Which of the following is true for the active region of an npn transistor?

- a) The collector current is directly proportional to the base current
- b) The potential difference between the emitter and the collector is less than 0.4 V
- c) All of the mentioned
- d) None of the mentioned

Answer: c

Explanation: The base current and the collector current are directly proportional to each other and the potential difference between the collector and the base is always less than 0.4 V.

5. Which of the following is true for the saturation region of BJT transistor?

- a) The collector current is inversely proportional to the base current
- b) The collector current is proportional to the square root of the collector current
- c) The natural logarithm of the collector current is directly proportional to the base current
- d) None of the mentioned

Answer: b

Explanation: The collector current is directly proportional to the base current in the saturation region of the BJT.

6. Which of the following is true for a npn transistor in the saturation region?

- a) The potential difference between the collector and the base is approximately 0.2V
- b) The potential difference between the collector and the base is approximately 0.3V
- c) The potential difference between the collector and the base is approximately 0.4V
- d) The potential difference between the collector and the base is approximately 0.5V

Answer: d

Explanation: The commonly used npn transistors have a potential difference of around 0.5V between the collector and the base.

7. The potential difference between the base and the collector  $V_{cb}$  in a pnp transistor in saturation region is \_\_\_\_\_

- a) -0.2 V
- b) -0.5V
- c) 0.2 V
- d) 0.5 V

Answer: b

Explanation: The value of  $V_{cb}$  is -0.5V for a pnp transistor and 0.5V for an npn transistor.

8. For a pnp transistor in the active region the value of  $V_{ce}$  (potential difference between the collector and the base) is

- a) Less than 0.3V
- b) Less than 3V
- c) Greater than 0.3V
- d) Greater than 3V

Answer: a

Explanation: For a pnp transistor  $V_{ce}$  is less than 0.3V, for an npn transistor it is greater than 0.3V.

9. Which of the following is true for a pnp transistor in active region?

- a) CB junction is reversed bias and the EB junction is forward bias
- b) CB junction is forward bias and the EB junction is forward bias
- c) CB junction is forward bias and the EB junction is reverse bias
- d) CB junction is reversed bias and the EB junction is reverse bias

Answer: a

Explanation: Whether the transistor is npn or pnp, for it to be in active region the EB junction must be reversed bias and the CB junction must be forward bias.

10. Which of the following is true for a pnp transistor in saturation region?

- a) CB junction is reversed bias and the EB junction is forward bias
- b) CB junction is forward bias and the EB junction is forward bias
- c) CB junction is forward bias and the EB junction is reverse bias
- d) CB junction is reversed bias and the EB junction is reverse bias

Answer: b

Explanation: Whether the transistor in npn or pnp, for it be in saturation region the EB junction must be forward bias the CB junction must be forward bias.

11. Which of the following is not a part of a BJT?

- a) Base
- b) Collector
- c) Emitter
- d) None of the mentioned

Answer: d

Explanation: BJT consists of three semiconductor regions, base region, emitter region and collector region.

12. The number of pn junctions a BJT is/are

- a) 1
- b) 2
- c) 3
- d) 4

Answer: b

Explanation: There are two pn junctions, base-emitter junction and collector-emitter junction respectively.

13. In which of the following modes can a BJT be used?

- a) Cut-off mode
- b) Active mode
- c) Saturation mode
- d) All of the mentioned

Answer: d

Explanation: These three are the defined regions in which a BJT operates.

14. If a BJT is to be used as an amplifier, then it must operate in \_\_\_\_\_

- a) Cut-off mode
- b) Active mode
- c) Saturation mode
- d) All of the mentioned

Answer: b

Explanation: A BJT operates as an amplifiers in active mode and as a switch in cut-off or saturation mode.

15. If a BJT is to be used as a switch, it must operate in \_\_\_\_\_

- a) Cut-off mode or active mode
- b) Active Mode or saturation mode
- c) Cut-off mode or saturation mode
- d) Cut-off mode or saturation mode or active mode

Answer: c

Explanation: A BJT operates as an amplifiers in active mode and as a switch

16. In cut off mode

- a) The base-emitter junction is forward biased and emitter-collector junction is reversed biased
- b) The base-emitter junction is forward biased and emitter-collector junction is forward biased
- c) The base-emitter junction is reversed biased and emitter-collector junction is reversed biased
- d) The base-emitter junction is reversed biased and emitter-collector junction is forward biased

Answer: c

Explanation: In cut-off mode there is no current flowing through the BJT hence both junctions must be reversed biased else if either of them is forward biased then the current will flow.

17. On which of the following does the scale current not depends upon?

- a) Effective width of the base
- b) Charge of an electron
- c) Electron diffusivity
- d) Volume of the base-emitter junction

Answer: d

Explanation: The saturation current does not depends upon the volume of the base-emitter junction. Instead it depends upon the area of the cross section of the base-emitter junction in a direction perpendicular to the flow of current.

18. On which of the following does the collector current not depend upon?

- a) Saturation current
- b) Thermal voltage
- c) Voltage difference between the base and emitter
- d) None of the mentioned

Answer: d

Explanation: Collector current depends linearly on the saturation current and exponentially on the ratio of the voltage difference between the base and collector and thermal voltage.

19. The range for the transistor parameter also referred to as common-emitter current gain has a value of \_\_\_\_\_ for common devices.

- a) 50-200
- b) 400-600
- c) 750-1000
- d) > 1000

Answer: a

Explanation: Most commonly used transistors have a current gain of in the range of 50-200. Only some specially designed transistors have a current gain in the range of 1000.

20. The collector current  $I_c$  is related to the emitter current  $I_e$  by a factor  $k$ . If  $b$  is the transistor parameter then the value of  $k$  in terms of  $b$  is

- a)  $k = b/(b + 1)$
- b)  $k = (b + 1)/b$
- c)  $b = (k + 1)/k$
- d) None of the mentioned

Answer: a

Explanation:  $I_c = k I_e$  (given) and also  $I_e = (b + 1)/b I_c$  (standard result). Equating these two results we get  $k = b/(b + 1)$ .

21. The current amplification factor  $\beta$  is given by \_\_\_\_\_

- a)  $I_C/I_B$
- b)  $I_B/I_C$
- c)  $I_E/I_B$
- d)  $I_B/I_E$

Answer: a

Explanation: The current amplification factor ( $\beta$ ) is given by  $I_C/I_B$ . When no signal is applied, then the ratio of collector current to the base current is called current amplification factor of a transistor.



22. In an NPN silicon transistor,  $\alpha=0.995$ ,  $I_E=10\text{mA}$  and leakage current  $I_{CBO}=0.5\mu\text{A}$ . Determine  $I_{CEO}$ .

- a)  $10\mu\text{A}$
- b)  $100\mu\text{A}$
- c)  $90\mu\text{A}$
- d)  $500\mu\text{A}$

Answer: b

Explanation:  $I_C = \alpha I_E + I_{CBO} = 0.995 \times 10\text{mA} + 0.5\mu\text{A} = 9.9505\text{mA}$ .

$I_B = I_E - I_C = 10 - 9.9505 = 0.0495\text{mA}$ .  $\beta = \alpha / (1 - \alpha) = 0.995 / (1 - 0.995) = 199$

$I_{CEO} = 9.9505 - 199 \times 0.0495 = 0.1\text{mA} = 100\mu\text{A}$ .

23. A germanium transistor with  $\alpha=0.98$  gives a reverse saturation current  $I_{CBO}=10\mu\text{A}$  in a CB configuration. When it is used in CE configuration with a base current of  $0.22\mu\text{A}$ , calculate the collector current.

- a)  $0.9867\text{mA}$
- b)  $0.7654\text{mA}$
- c)  $0.51078\text{mA}$
- d)  $0.23456\text{mA}$

Answer: c

Explanation: Given,  $I_{CBO}=10\mu\text{A}$ ,  $\alpha=0.98$  and  $I_B = 0.22\mu\text{A}$ .  $I_C = \alpha / (1 - \alpha) I_B + 1 / (1 - \alpha) I_{CBO}$

$0.01078 + 0.5 = 0.51078\text{mA}$ .

24. In CE configuration, if the voltage drop across  $5\text{k}\Omega$  resistor connected in the collector circuit is  $5\text{V}$ . Find the value of  $I_B$  when  $\beta=50$ .

- a)  $0.01\text{mA}$
- b)  $0.25\text{mA}$
- c)  $0.03\text{mA}$
- d)  $0.02\text{mA}$

Answer: d

Explanation:  $I_C = V$  across  $R_L / R_L = 5\text{V} / 5\text{k}\Omega = 1\text{mA}$ .

$I_B = I_C / \beta = 1 / 50 = 0.02\text{mA}$ .

25. A transistor is connected in CE configuration. Collector supply voltage  $V_{CC}=10\text{V}$ ,  $R_L=800\Omega$ , voltage drop across  $R_L=0.8\text{V}$ ,  $\alpha=0.96$ . What is base current?

- a)  $41.97\mu\text{A}$
- b)  $56.78\mu\text{A}$
- c)  $67.67\mu\text{A}$
- d)  $78.54\mu\text{A}$

Answer: a

Explanation: Here,  $I_C = 0.8 / 800 = 1\text{mA}$

$\beta = \alpha / (1 - \alpha) = 0.96 / 1 - 0.96 = 24$ .

Now,  $I_B = I_C / \beta = 1 / 24 = 41.67\mu\text{A}$ .

27. The relation between  $\alpha$  and  $\beta$  is \_\_\_\_\_

- a)  $\beta = \alpha / (1 - \alpha)$
- b)  $\alpha = \beta / (1 + \beta)$
- c)  $\beta = \alpha / (1 + \alpha)$
- d)  $\alpha = \beta / (1 - \beta)$

Answer: b

Explanation:  $\beta$  is an ac base amplification factor. is called as current amplification factor. The relation of  $I_C$  and  $I_B$  change as  $I_C = \beta I_B + (1 + \beta) I_{CBO}$ .

28. In  $I_{CEO}$ , wt does the subscript 'CEO' mean?

- a) collector to base emitter open
- b) emitter to base collector open
- c) collector to emitter base open
- d) emitter to collector base open

Answer: c

Explanation: The subscript 'CEO' means that it is collector to emitter base open. It is called as the leakage current. It occurs in a reverse bias in PNP transistor. The total current can be calculated by  $I_C = \beta I_B + I_C$ .

29. When the signal is applied, the ratio of change of collector current to the ratio of change of base current is called \_\_\_\_\_

- a) dc current gain
- b) base current amplification factor
- c) emitter current amplification factor
- d) ac current gain

Answer: d

Explanation: The ac current gain is given by  $\beta = \Delta I_C / \Delta I_B$ . When the signal is applied, the ratio of change of collector current to the ratio of change of base current is called ac current gain.

30. The range of  $\beta$  is \_\_\_\_\_

- a) 20 to 500
- b) 50 to 300
- c) 30 to 400
- d) 10 to 20

Answer: a

Explanation: Almost in all the transistors, the base current is less than 5% of the emitter current. Due to this fact, it is generally greater than 20. Usually it ranges from 20 to 500. Hence this configuration is frequently used when appreciable current gain as well as voltage gain is required

31. The AC current gain in a common base configuration is\_\_\_\_\_

- a)  $-\Delta I_C/\Delta I_E$
- b)  $\Delta I_C/\Delta I_E$
- c)  $\Delta I_E/\Delta I_C$
- d)  $-\Delta I_E/\Delta I_C$

Answer: a

Explanation: The AC current gain is denoted by  $\alpha_{ac}$ . The ratio of change in collector current to the change in emitter current at constant collector base voltage is defined as current amplification factor.

32. The value of  $\alpha_{ac}$  for all practical purposes, for commercial transistors range from\_\_\_\_\_

- a) 0.5-0.6
- b) 0.7-0.77
- c) 0.8-0.88
- d) 0.9-0.99

Answer: d

Explanation: For all practical purposes,  $\alpha_{ac}=\alpha_{dc}=\alpha$  and practical values in commercial transistors range from 0.9-0.99. It is the measure of the quality of a transistor. Higher is the value of  $\alpha$ , better is the transistor in the sense that collector current approaches the emitter current.

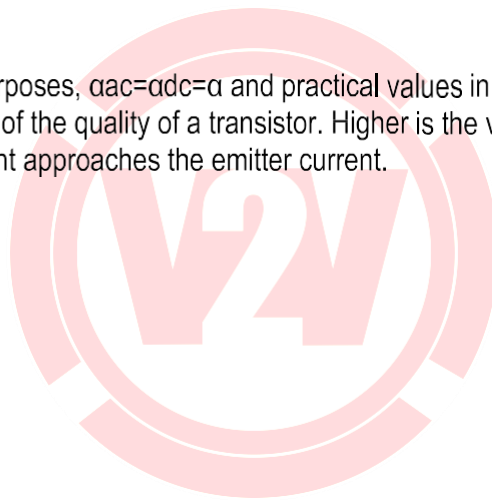

33. A transistor has an  $I_C$  of 100mA and  $I_B$  of 0.5mA. What is the value of  $\alpha_{dc}$ ?

- a) 0.787
- b) 0.995
- c) 0.543
- d) 0.659

Answer: b

Explanation: Emitter current  $I_E=I_C+I_B =100+0.5=100.5\text{mA}$   
 $\alpha_{dc}=I_C/I_E=100/100.5=0.995$ .

34. In CB configuration, the value of  $\alpha=0.98$ . A voltage drop of 4.9V is obtained across the resistor of  $5K\Omega$  when connected in collector circuit. Find the base current.

- a) 0.01mA
- b) 0.07mA
- c) 0.02mA
- d) 0.05mA

Answer: c

Explanation: Here,  $I_C=4.9/5K=0.98mA$

$\alpha = I_C/I_E$  .So,

$I_E=I_C/\alpha=0.98/0.98=1mA$ .

$I_B=I_E-I_C=1-0.98=0.02mA$ .

35. The emitter current  $I_E$  in a transistor is 3mA. If the leakage current  $I_{CBO}$  is  $5\mu A$  and  $\alpha=0.98$ , calculate the collector and base current.

- a) 3.64mA and  $35\mu A$
- b) 2.945mA and  $55\mu A$
- c) 3.64mA and  $33\mu A$
- d) 5.89mA and  $65\mu A$

Answer: b

Explanation:  $I_C=\alpha I_E + I_{CBO}$

$=0.98*3+0.005=2.945mA$ .

$I_E=I_C+I_B$  . So,  $I_B=3-2.945=0.055mA=55\mu A$ .

36. Determine the value of emitter current and collector current of a transistor having  $\alpha=0.98$  and collector to base leakage current  $I_{CBO}=4\mu A$ . The base current is  $50\mu A$ .

- a) 1.5mA
- b) 3.7mA
- c) 2.7mA
- d) 4.5mA

Answer: c

Explanation: Given,  $I_B=50\mu A=0.05mA$

$I_{CBO}=4\mu A=0.004mA$

$I_C=\alpha/(1-\alpha)I_B+1/(1-\alpha)I_{CBO}=2.45+0.2=2.65mA$

$I_E=I_C+I_B=2.65+0.05=2.7mA$ .

37. The negative sign in the formula of amplification factor indicates \_\_\_\_\_

- a) that IE flows into transistor while IC flows out it
- b) that IC flows into transistor while IE flows out it
- c) that IB flows into transistor while IC flows out it
- d) that IC flows into transistor while IB flows out it

Answer: a

Explanation: When no signal is applied, the ratio of collector current to emitter current is called dc alpha,  $\alpha_{dc}$  of a transistor.  $\alpha_{dc} = I_C/I_E$ . It is the measure of the quality of a transistor. Higher is the value of  $\alpha$ , better is the transistor in the sense that collector current approaches the emitter current.

38. The relation between  $\alpha$  and  $\beta$  is \_\_\_\_\_

- a)  $\beta = \alpha/(1-\alpha)$
- b)  $\alpha = \beta/(1+\beta)$
- c)  $\beta = \alpha/(1+\alpha)$
- d)  $\alpha = \beta/(1-\beta)$

Answer: b

Explanation:  $\beta$  is an ac base amplification factor.  $\alpha$  is called as current amplification factor. The relation of IC and IB change as  $I_C = \beta I_B + (1 + \beta) I_{CBO}$ .

39. A transistor has an IE of 0.9mA and amplification factor of 0.98. What will be the IC?

- a) 0.745mA
- b) 0.564mA
- c) 0.236mA
- d) 0.882mA

Answer: d

Explanation: Given,  $I_E = 0.9\text{mA}$ ,  $\alpha = 0.98$

We know,  $\alpha = I_C/I_E$

So,  $I_C = 0.98 \times 0.9 = 0.882\text{mA}$ .

40. The collector current is 2.945A and  $\alpha = 0.98$ . The leakage current is  $2\mu\text{A}$ . What is the emitter current and base current?

- a) 3mA and  $55\mu\text{A}$
- b) 2.945mA and  $55\mu\text{A}$
- c) 3.64mA and  $33\mu\text{A}$
- d) 5.89mA and  $65\mu\text{A}$

Answer: a

Explanation:  $(I_C - I_{CBO})/\alpha = I_E$

$= (2.945 - 0.002)/0.98 = 3\text{mA}$ .

$I_E = I_C + I_B$ . So,  $I_B = 3 - 2.945 = 0.055\text{mA} = 55\mu\text{A}$ .

41. The current amplification factor  $\alpha_{c}$  is given by \_\_\_\_\_

- a)  $I_E/I_B$
- b)  $I_B/I_E$
- c)  $I_C/I_E$
- d)  $I_E/I_C$

Answer: a

Explanation: When no signal is applied, then the ratio of emitter current to base current is called the transistor. As the collector is common to both input and output circuits, hence the name common collector configuration.

42. The relation between  $\alpha$  and  $\beta$  is given by \_\_\_\_\_

- a)  $1/(1-\alpha)=1-\beta$
- b)  $1/(1+\alpha)=1+\beta$
- c)  $1/(1-\alpha)=1+\beta$
- d)  $1/(1+\alpha)=1-\beta$

Answer: c

Explanation: The current amplification factor ( $\beta$ ) is given by  $I_C/I_B$ . When no signal is applied, then the ratio of collector current to the base current is called current amplification factor of a transistor.  $\beta$  is an ac base amplification factor.  $\alpha$  is called as current amplification factor. The relation of  $I_C$  and  $I_B$  change as  $I_C = \beta I_B + (1 + \beta) I_{CBO}$ .

43. The CC configuration has an input resistance \_\_\_\_\_

- a)  $500k\Omega$
- b)  $750k\Omega$
- c)  $600k\Omega$
- d)  $400k\Omega$

Answer: b

Explanation: It has a high input resistance and very low output resistance so the voltage gain is always less one. It is used for driving a low impedance load from a high impedance source.

44. The application of a CC configured transistor is \_\_\_\_\_

- a) voltage multiplier
- b) level shifter
- c) rectification
- d) impedance matching

Answer: d

Explanation: The most important use of CC transistor is an impedance matching device. It is seldom used for amplification purposes. The current gain is same as that of CE configured transistor.

45. What is the output resistance of CC transistor?

- a) 25  $\Omega$
- b) 50  $\Omega$
- c) 100  $\Omega$
- d) 150  $\Omega$

Answer: a

Explanation: The CC transistor has a very low value of output resistance of 25  $\Omega$ . The voltage gain always less one. It is used for driving a low impedance load from a high impedance source.

46. Increase in collector emitter voltage from 5V to 8V causes increase in collector current from 5mA to 5.3mA. Determine the dynamic output resistance.

- a) 20k $\Omega$
- b) 10k $\Omega$
- c) 50k $\Omega$
- d) 60k $\Omega$

Answer: b

Explanation:  $r_o = \Delta V_{CE} / \Delta I_C$   
 $= 3 / 0.3\text{m} = 10\text{k}\Omega$ .

47. A change in 300mV in base emitter voltage causes a change of 100 $\mu$ A in the base current. the dynamic input resistance.

- a) 20k $\Omega$
- b) 10k $\Omega$
- c) 30k $\Omega$
- d) 60k $\Omega$

Answer: c

Explanation:  $r_i = \Delta V_{BE} / \Delta I_B$   
 $= 300\text{m} / 100\mu = 30\text{k}\Omega$ .

48. The point on the DC line which is called \_\_\_\_\_

- a) cut off point
- b) cut in point
- c) breakdown point
- d) operating point

Answer: d

Explanation: The point which represents the values of  $I_C$  and  $V_{CE}$  that exist in a transistor circuit when no signal is applied is called as operating point. This is also called as working point or quiescent point.

49. When is the transistor said to be saturated?

- a) when VCE is very low
- b) when VCE is very high
- c) when VBE is very low
- d) when VBE is very high

Answer: a

Explanation: When VCE is very low, the transistor is said to be saturated and it operates in the saturated region of characteristic. The change in base current  $I_B$  does not produce a corresponding change in the collector current  $I_C$ .

50. The input resistance is given by \_\_\_\_\_

- a)  $\Delta V_{CE}/\Delta I_B$
- b)  $\Delta V_{BE}/\Delta I_B$
- c)  $\Delta V_{BE}/\Delta I_C$
- d)  $\Delta V_{BE}/\Delta I_E$

Answer: b

Explanation: The ratio of change in base emitter voltage ( $\Delta V_{BE}$ ) to resulting change in base current ( $\Delta I_B$ ) at constant collector emitter voltage (VCE) is defined as input resistance. This is denoted by  $r_i$ .

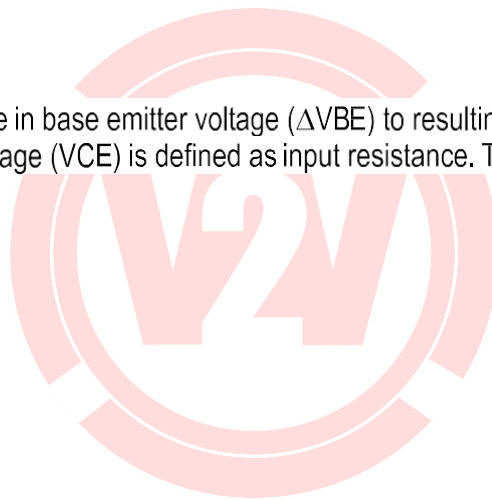



1. To bias a e-MOSFET \_\_\_\_\_
- a) we can use either gate bias or a voltage divider bias circuit
  - b) we can use either gate bias or a self bias circuit
  - c) we can use either self bias or a voltage divider bias circuit
  - d) we can use any type of bias circuit

Answer: a

Explanation: To bias an e-MOSFET, we cannot use a self bias circuit because the gate to source voltage for such a circuit is zero. Thus, no channel is formed and without the channel, the MOSFET doesn't work properly. If self bias circuit is used, then D-MOSFET can be operated in depletion mode.

2. JFET is a \_\_\_\_\_ carrier device.
- a) Unipolar
  - b) Bipolar
  - c) Minority
  - d) Majority

Answer: d

Explanation: The current flow in the device is due to majority carriers. In an n-type JFET, it is due to the electrons and in a p-type JFET- it is due to the holes.

3. The n-channel JFET, the pinch off voltage is \_\_\_\_\_
- a) not greater than 0
  - b) greater than or equal to 0
  - c) less than or equal to 0
  - d) not less than 0

Answer: a

Explanation: The pinch off voltage for an N-channel JFET is negative. The depletion region would extend into the N-channel if the reverse bias in the gate to source voltage increases which means that the gate to source voltage has to be negative since the gate is N-type.

4. The built-in barrier potential in a N-channel JFET is \_\_\_\_\_
- a) less than the internal pinch-off voltage
  - b) equal to the internal pinch-off voltage
  - c) greater than the internal pinch-off voltage
  - d) not related to the internal pinch-off voltage

Answer: a

Explanation: Pinch-off would require more voltage than the voltage required to establish the p-n barrier voltage. This is evident from the dependence of such voltage on the doping concentration.

5. If channel thickness increases, the internal pinch-off voltage \_\_\_\_\_

- a) Decreases
- b) Increases
- c) Remains the same
- d) Increases logarithmically

Answer: b

Explanation: The internal pinch off voltage is directly proportional to the channel thickness. If the channel thickness increases, the pinch off voltage increases.

6. If the doping concentration of the gate \_\_\_\_\_ internal pinch-off voltage \_\_\_\_\_

- a) Increases logarithmically
- b) Increases linearly
- c) Increases exponentially
- d) Decreases linearly

Answer: b

Explanation: The internal pinch-off voltage is linearly proportional to the doping concentration. Hence, it would increase with the increase in the doping concentration. The built-in-barrier potential is logarithmically proportional to the doping concentration of the gate.

7. The cut-off frequency of a JFET is that time when the magnitude of the input current is \_\_\_\_\_

- a) Greater than the output current
- b) Less than the output current
- c) Equal to the output current
- d) Twice the output current

Answer: c

Explanation: The cut-off frequency is an important feature of the JFET due to the present of capacitive effects. It has been seen that the output current becomes a function of frequency in high-frequency applications and hence we have to choose a cut-off frequency so that the output current is equal to the input current.

8. The cut-off frequency of a JFET is \_\_\_\_\_

- a) linearly related to the transconductance of the JFET
- b) inversely proportional to the transconductance of the JFET
- c) exponentially related to the transconductance of the JFET
- d) logarithmically related to the transconductance of the JFET

Answer: a

Explanation: The cut-off frequency is seen to be linearly related to the transconductance of the JFET. is typically due to the reactance of the capacitors.

9. How is the transconductance at saturation related to the pinch off voltage of the JFET?

- a) Inversely proportional
- b) Directly proportional
- c) Inverse-squarely related
- d) Directly and proportional to square of the pinch-off voltage

Answer: a

Explanation: The transconductance is seen to be inversely related to the pinch of voltage. The

10. When an N-channel JFET reaches pinch-off, the increase in the drain to source voltage results in shifting of the pinch-off position towards the \_\_\_\_\_

- a) Gate
- b) Drain
- c) Source
- d) Does not shift

Answer: c

Explanation: Pinch off is said to be reached if the drain to source voltage is equal to the difference between the gate to source and the threshold voltage. So, this pinch off happens at a certain distance from the source and the gradual decrease in the channel length will happen faster if the voltage along the channel length increases faster. It can be readily observed that equality is reached at a distance less than the previous case and hence the pinch-off is shifted towards the source

11. An N-channel JFET is \_\_\_\_\_

- a) Always ON
- b) Always OFF
- c) Enhancement mode JFET
- d) Has a p-type substrate

Answer: a

Explanation: An N-channel is always ON depletion mode JFET since the channel for current flow from source to drain is always present. This is in contrast to a P-channel JFET which needs to be provided with a channel for the flow of current.

12. A P-channel JFET is \_\_\_\_\_

- a) Always ON
- b) Always OFF
- c) Depletion mode JFET
- d) Has an n-type substrate

Answer: b

Explanation: The P-channel JFET doesn't have a built-in channel for the flow of current. This is because the conduction in a P-channel JFET can begin after a certain voltage is applied at the gate which would lead to widening the channel between the source and the drain.

13. How is the metallurgical channel thickness between the gate and the substrate related to the doping concentration of the channel?

- a) Inversely proportional to the square root of the doping concentration
- b) Logarithmically related to the square root of the doping concentration
- c) Directly proportional to the square root of the doping concentration
- d) Exponentially related to the square root of the doping concentration

Answer: a

Explanation: The channel thickness is inversely related to the square root of the doping concentration of the channel. This is because the electric field developed is proportional to the channel doping concentration while the relation between the potential, electric field and doping concentration is visible from the Poisson's equation.

14. What are the small signal FET parameters?

- a) gm and rds
- b) gm and Vgs
- c) Vds and rds
- d) gm

Answer: a

Explanation: The small signal model of FET- MOSFET and JFET is obtained from the following equation  
 $I_{DS} = g_m V_{gs} + V_{ds}/r_{ds}$   
gm and rds are the small signal FET parameters.

15. For low value of VDS, the JFET behaves like a \_\_\_\_\_

- a) Voltage Variable Resistor
- b) Constant Voltage Device
- c) Amplifier
- d) Switch

Answer: a

Explanation: When VDS voltage is very less, there will not be much current flow, since as the VDS changes, the current value changes very little. Hence we can say that FET works as a voltage controlled Resistor.

16. If a JFET with length  $L=10\mu\text{m}$ ,  $a=2\mu\text{m}$ ,  $W=8\mu\text{m}$ ,  $V_p=-4\text{V}$ . What is the value of rds at  $V_{gs} = 0\text{V}$ ?

- a)  $2\text{K}\Omega$
- b)  $5.2\text{K}\Omega$
- c)  $10\text{K}\Omega$
- d)  $9.8\text{K}\Omega$

Answer: d

Explanation:  $r_{ds} = L / (2aqND \mu_n W) = Nd = 2V / qa^2 = 1.33 \times 10^{21} \text{ atoms/m}^3$   
 $\mu_n = 0.15 \text{ m}^2/\text{v-sec}$

On substituting the values, we get  $r_{ds} = 9.8\text{K}\Omega$ .

17. A JFET has  $I_D=10\text{mA}$ ,  $I_{DSS}=1\text{A}$ ,  $V_p=-1\text{v}$ , what is the value of  $V_{gs}$ ?

- a) -0.9V
- b) 1V
- c) -1V
- d) 0.5V

Answer: a

$$V_{gs} = V_p (1 - \sqrt{I_D/I_{DSS}}) \Rightarrow V_{gs} = -1(1 - \sqrt{0.01/1})$$

Explanation:  $\Rightarrow V_{gs} = -1(0.9) \Rightarrow -0.9\text{V}$ .

18. Where does the transfer curve lie for a p- channel FET?

- a) First quadrant
- b) Second quadrant
- c) Third quadrant
- d) Fourth quadrant

Answer: a

Explanation: For a P- channel FET, since the pinch off lies on right side of the origin, the current  $I_d$  will increase from  $V_p$  and rise to its left until it reaches  $I_{DSS}$ . Usually  $I_{DSS}$  lies on positive Y axis, therefore we can say transfer curve for the p-channel FET lies on first quadrant.

19. For an n-channel FET, the current  $i$  at  $V_{gs}=-2\text{V}$  and  $V_{ds}=5\text{V}$  was found to be  $2\text{mA}$ , what will be the value of  $I_D$  at  $V_{gs}=0\text{V}$  and  $V_{ds}=5\text{V}$ ?

- a) 0A
- b) 2mA
- c) Lesser than 0A
- d) Greater than 2mA

Answer: d

Explanation: We know that for a n channel FET, the current will flow only if  $V_{gs}$  is greater than  $V_p$ , since in this case current is flowing, which indicates  $V_{gs}$  is greater than pinch off. But as  $V_{gs}$  increases the flow of current also increases, hence it will be greater than  $2\text{mA}$ .

20. For a p-channel FET, the current  $I_D$  at  $V_{GS} = 2V$  and  $V_{DS} = 5V$  and  $V_{GS} = 3V$  was found to be  $2mA$ , what will be the value of  $I_D$  at  $V_{GS} = 0V$  and  $V_{DS} = 5V$ ?

- a)  $0A$
- b)  $2mA$
- c) Lesser than  $0A$
- d) Greater than  $2mA$

Answer: a

Explanation: We know that for a p channel FET, the current will flow only if  $V_{GS}$  is lesser than  $V_{GS}$ , but here pinch off voltage is  $3V$ , when  $V_{GS}=5V$  which is greater than pinch off voltage the channel will be destroyed resulting in no conventional current flow.

21. A FET is biased at  $I_D = I_{DSS}/4$ , at this point the value of trans conductance is \_\_\_\_\_  
( $I_D=10mA$ ,  $V_p=-5V$ ).

- a)  $1mA/V$
- b)  $2mA/V$
- c)  $3mA/V$
- d)  $4mA/V$

Answer: b

$$g_m = g_{mo} \sqrt{I_D / I_{DSS}} = (2I_{DSS} / |V_p|) \sqrt{\frac{I_{DSS}}{4} / I_{DSS}}$$

$$\Rightarrow (2 \times 10mA / 5) \left( \sqrt{\frac{15mA}{4} / 15mA} \right)$$

Explanation:  $= 2mA/V$ .

22. What is the value of resultant  $g_m$  if two non identical FETs are connected in parallel?

- a)  $(\mu_1 r_{d1} + \mu_2 r_{d2}) / (r_{d1} + r_{d2})$
- b)  $(\mu_1 r_{d2} + \mu_2 r_{d1}) / (r_{d1} + r_{d2})$
- c)  $0$
- d)  $\mu_1 r_{d1} + \mu_2 r_{d2}$

Answer: b

Explanation: we know that  $\mu = g_m r_d$

But  $g_m' = g_{m1} + g_{m2}$

And  $r_{d}' = r_{d1} \times r_{d2} / r_{d1} + r_{d2}$

From the above two equations,  $g_m' = (\mu_1 r_{d2} + \mu_2 r_{d1}) / (r_{d1} + r_{d2})$ .

23. What will be the value of  $r_d$ , if two identical FETs are connected in parallel?

- a) Doubles
- b) Reduces to half
- c) 0
- d) Infinite

Answer: b

Explanation:  $r_d' = r_{d1} \times r_{d1} / r_{d1} + r_{d2}$

If  $r_{d1} = r_{d2} = r_d \Rightarrow$  then  $r_d' = r_d / 2$

24. What will be the value of trans conductance if two identical FETs are connected in parallel?

- a) Doubles
- b) Reduces to half
- c) 0
- d) Infinite

Answer: a

Explanation:  $g_m' = I_{DS} / V_{gs}$  at  $V_{DS} = 0V$ , if two FET are identical then,

$g_{m1} = g_{m2} = g_m$

But  $g_m' = g_{m1} + g_{m2}$

Therefore  $g_m' = g_m + g_m = 2g_m$ .

25. What is pinch off voltage?

- a) The minimum voltage required to turn on the FET
- b) The maximum voltage a FET can withstand
- c) Current amplification factor/voltage gain
- d) The value of voltage at which the current gets pinched to zero

Answer: d

Explanation: Once the voltage difference between the gate and source goes near to the pinch off voltage, the channel will get pinched off resulting in off state of the FET, which makes no conventional current flow.

26. A p-channel Ge JFET has max-half channel width  $5\mu m$  and channel conductivity of  $2/\Omega cm$ , if  $E_r = 2000 cm^2/Vsec$ , What is the value of pinch off voltage?

- a) 8.21V
- b) 82.1V
- c) 88.21V
- d) 5.2V

Answer: c

Explanation:  $V_p = qNA a^2 / 2E$

$= (5 \times 10^{-4}) (5 \times 10^{-4}) \times 2 / (2 \times 16 \times 8.854 \times 2000 \times 10^{-14})$

$= 88.21V$ .

27. What will happen if gate voltage applied is positive to pinch off voltage?

- a) Device burns
- b) More current flows
- c) Nothing happens
- d) Current remains the same

Answer: a

Explanation: When the voltage applied across the gate terminal becomes more positive, all of the will start flowing from drain to gate terminal. This results in breaking of insulator layer, resulting in device destruction.

28. How does a FET behave when the v-I characteristics are to the left of pinch off for an n channel FET?

- a) Voltage controlled resistor
- b) Amplifier
- c) Switch
- d) Diode

Answer: a

Explanation: When the voltage  $V_{gs}$  is less than pinch off voltage, there will be no current flow, resulting Ohmic region, on controlling the  $V_{gs}$  and  $V_{Ds}$  values, the FET acts as Voltage controlled resistor.

29. What is the relation between the drain current and source current once the voltage crosses pinch off?

- a)  $I_D = I_S$
- b)  $I_D = I_S + 1.5$
- c)  $I_D = 1/I_S$
- d)  $I_S - 2I_D = 0$

Answer: a

Explanation: For a FET, once the voltage exceeds the pinch off voltage, the electrons will start flowing from source to drain or vice versa, since no current flows through the gate terminal, the current transfer takes place only between the drain and source. Hence  $I_D = I_S$ .

30. If a FET has a pinch off voltage  $= -1V$  and  $I_D = 1mA$ , If  $V_{gs} = 0V$ , What is the value of  $I_{DSS}$ ?

- a) 1A
- b) 1mA
- c) 0A
- d) 100mA

Answer: b

Explanation:  $I_D = I_{DSS} (1 - V_{gs}/V_p)^2$

$V_{gs} = 0V \Rightarrow I_D = I_{DSS} = 1mA$ .



31. For what value of  $V_{gs}$ , the drain current will be 1/4th of its maximum current?

- a) 0
- b) 1
- c)  $V_p$
- d)  $V_p/2$

Answer: d

Explanation:  $I_D = I_{DSS} (1 - V_{gs}/V_p)^2$

When  $I_D = I_{DSS}/4 \Rightarrow (1 - V_{gs}/V_p)^2 = 1/4$

$\Rightarrow (1 - V_{gs}/V_p)^2 = 1/2$

$\Rightarrow V_{gs} = V_p/2$ .

32. For a n-channel FET, what is the condition of  $V_{gs}$  for which the current becomes zero?

- a) 0
- b) 100V
- c)  $V_p$
- d) Infinite

Answer: c

Explanation:  $I_D = I_{DSS} (1 - V_{gs}/V_p)^2$

When  $I_D = 0$ ,  $(1 - V_{gs}/V_p)^2 = 0$

$1 - V_{gs}/V_p \Rightarrow V_{gs} = V_p$ .

33. For a FET having  $I_{DSS} = 2\text{mA}$ ,  $V_{gs} = 2\text{V}$  and  $V_p = -1\text{V}$ , What is the value of source current?

- a) 9mA
- b) 18mA
- c) 3mA
- d) 1mA

Answer: b

Explanation:  $I_D = I_{DSS} (1 - V_{gs}/V_p)^2$

$I_D = I_S = 2 \times (1 + 2)(1 + 2) = 32 \times 2 = 18\text{mA}$

$I_S = 18\text{mA}$ .

34. Find the current through gate if the FET was given with gate to source voltage = 10V and drain to source voltage = 20V, the pinch off voltage was -2V and  $I_D = 2\text{mA}$ .

- a) 10mA
- b) 20mA
- c) 0mA
- d) 2mA

Answer: c

Explanation: We know that for a FET, the gate terminal is heavily doped with an insulator, resulting in infinite resistance. Hence no current flows through the gate terminal. It has no relationship with the other current parameters. It is constant for all FETs.

35. If a MOSFET is to be used in the making of an amplifier then it must work in

- a) Cut-off region
- b) Triode region
- c) Saturation region
- d) Both cut-off and triode region can be used

Answer: c

Explanation: Only in the saturation region a MOSFET can operate as an amplifier.

36. For MOSFET is to be used as a switch then it must operate in

- a) Cut-off region
- b) Triode region
- c) Saturation region
- d) Both cut-off and triode region can be used

Answer: d

Explanation: In both regions it can perform the task of a switch.

37. In the saturation region of the MOSFET the saturation current is?

- a) Independent of the voltage difference between the source and the drain
- b) Depends directly on the voltage difference between the source and the drain
- c) Depends directly on the overdriving voltage
- d) Depends directly on the voltage supplied to the gate terminal

Answer: a

Explanation: Saturation current does not depend on the voltage difference between the source and the drain in the saturation region of a MOSFET.

38. An n-channel MOSFET operating with  $V_{OV}=0.5V$  exhibits a linear resistance =  $1k\Omega$  when  $V_{DS}$  is very small. What is the value of the device transconductance parameter  $k_n$ ?

- a)  $2 \text{ mA/V}^2$
- b)  $20 \text{ mA/V}^2$
- c)  $0.2 \text{ A/V}^2$
- d)  $2 \text{ A/V}^2$

Answer: a

Explanation: Use the standard mathematical expression to determine the value of  $k_n$ .

39. An NMOS transistor is operating at the edge of saturation with an overdrive voltage  $V_{OV}$  and a drain current  $I_D$ . If  $V_{OV}$  is doubled, and we must maintain operation at the edge of saturation, what value of drain current results?

- a)  $0.25I_D$
- b)  $0.5I_D$
- c)  $2I_D$
- d)  $4I_D$

Answer: c

Explanation:  $I_D$  is directly proportional to  $V_{OV}^2$ .

40. A discrete MOSFET common source amplifier has  $R_{in} = 2\text{ M}\Omega$ ,  $g_{m1} = 4\text{ mA/V}$ ,  $r_{o1} = 100\text{ k}\Omega$ ,  $R_D = 10\text{ k}\Omega$ ,  $C_{gs} = 2\text{ pF}$  and  $C_{gd} = 0.5\text{ pF}$ . The amplifier is fed from a voltage source with an internal resistance of  $500\text{ k}\Omega$  and is connected to a load of  $10\text{ k}\Omega$ . The value of the overall mixed gain  $A_M$  is?

- a)  $-15.2\text{ V/V}$
- b)  $-16.2\text{ V/V}$
- c)  $-17.2\text{ V/V}$
- d)  $-18.2\text{ V/V}$

Answer: a

41. A discrete MOSFET common source amplifier has  $R_{in} = 2\text{ M}\Omega$ ,  $g_{m1} = 4\text{ mA/V}$ ,  $r_{o1} = 100\text{ k}\Omega$ ,  $R_D = 10\text{ k}\Omega$ ,  $C_{gs} = 2\text{ pF}$  and  $C_{gd} = 0.5\text{ pF}$ . The amplifier is fed from a voltage source with an internal resistance of  $500\text{ k}\Omega$  and is connected to a load of  $10\text{ k}\Omega$ . The upper 3-dB frequency  $f_H$  is?

- a)  $11.1\text{ kHz}$
- b)  $22.1\text{ kHz}$
- c)  $33.1\text{ kHz}$
- d)  $44.1\text{ kHz}$

Answer: c

42. For a particular depletion mode NMOS device,  $V_t = -2\text{ V}$ ,  $k_n W/L = 200\text{ }\mu\text{A/V}^2$  and  $\lambda = 0.02\text{ V}^{-1}$ . For  $V_{DS} = 2\text{ V}$ . What is the drain current that flows

- a)  $104\text{ }\mu\text{A}$
- b)  $208\text{ }\mu\text{A}$
- c)  $312\text{ }\mu\text{A}$
- d)  $416\text{ }\mu\text{A}$

Answer: d

43. For a particular depletion mode NMOS device,  $V_t = -2V$ ,  $k_n W/L = 200 \mu A/V^2$  and  $\lambda = 0.02V^{-1}$ . For  $V_{DS} = 2V$ . What is the value of the drain current if both L and W are doubled?

- a) 408  $\mu A$
- b) 412  $\mu A$
- c) 416  $\mu A$
- d) 420  $\mu A$

Answer: a

44. A depletion type N channel MOSFET with  $k_n W/L = 2 mA/V^2$  and  $V_t = 3V$  has its source and gate grounded. For  $V_d = 0.1V$  and neglecting channel length modulating effect. Find drain current.

- a) 1.18 mA
- b) 0.89 mA
- c) 0.59 mA
- d) 0.3 mA

Answer: b

45. A depletion type N channel MOSFET with  $k_n W/L = 2 mA/V^2$  and  $V_t = 3V$  has its source and gate grounded. For  $V_d = 0.1V$  and neglecting channel length modulating effect. In which region is the triode operating?

- a) Triode region
- b) End of saturation region
- c) Saturation region
- d) None of the mentioned

Answer: a

46. In which of the following configuration does a MOSFET works as an amplifier?

- a) Common Source (CS)
- b) Common Gate (CG)
- c) Common drain (CD)
- d) All of the mentioned

Answer: d

**Explanation:** There are three basic configurations for connecting the MOSFET as an amplifier. Each of these configurations is obtained by connecting one of the three MOSFET terminals to ground, thus creating a two-port network with the grounded terminal being common to the input and output ports.

47. Input resistance of common gate of the amplifier is \_\_\_\_\_

- a) zero
- b) infinity
- c) extremely low
- d) extremely high

Answer: c

Explanation: For a Common gate amplifier, Current gain is about unity, input resistance is low, output resistance is high a CG stage is a current "buffer". It takes a current at the input that may have a relatively small Norton equivalent resistance and replicates it at the output port, which is a good current source due to the high output resistance.

48. A FET circuit has a transconductance of  $2500 \mu$  seconds and drain resistance equals to 10Kohms than voltage gain will be \_\_\_\_\_

- a) 20
- b) 25
- c) 30
- d) 35

Answer: b

Explanation: The transconductance,  $g_m$  is defined as  
 $g_m = \Delta I_D / \Delta V_{GS}$

so  $g_m = \text{Voltage gain} / R_D$

Therefore, voltage gain =  $g_m * R_D$

=  $2500 * 10^{-6} * 10^4$

= 25

49. Voltage gain of common drain amplifier is always slightly less than \_\_\_\_\_

- a) 0.5
- b) 1
- c) 1.5
- d) 2

Answer: b

Explanation: In common drain amplifier

Writing KCL at the source node ;

$G_m(v_{in} - v_{out}) - g_{mbs} v_{out} - g_{ds} v_{out} = 0$

$v_{out} v_{in} = G_m / G_m + G_{mbs} + g_{ds}$

Therefore gain is less than one.

50. The drain of FET is analogous to BJT

- a) collector
- b) emitter
- c) base
- d) drain

Answer: a

Explanation: A common collector amplifier (also known as an emitter follower) is one of three basic single-stage bipolar junction transistor (BJT) amplifier, typically used as a voltage buffer.

In this circuit the base terminal of the transistor serves as the input, the emitter is the output, and the collector is common to both. The analogous field-effect transistor circuit is the common drain amplifier and the analogous tube circuit is the cathode follower.



1. Which of the following can be a source of supply in dc power supplies?

- a) Battery
- b) Dry cell
- c) Full wave rectifier
- d) All of the mentioned

Answer: d

Explanation: Source of supply will be a battery, dry cell or full wave rectifier etc.

2. Which of the application's filters used for?

- a) Reducing ripples
- b) Increasing ripples
- c) Increasing phase change
- d) Increasing amplitude

Answer: a

Explanation: Ripples are ac components and filters are used for eliminating ac components from a signal.

3. Which of the following represent a change of output voltage when load current is increased?

- a) Line regulation
- b) Load regulation
- c) Current regulation
- d) Voltage regulation

Answer: b

Explanation: Load regulation is the process of fractional change of output voltage when load current is increased from zero to maximum value.

4. \_\_\_\_\_ of the following generate output voltage much closer to true value?

- a) True generator
- b) Precision generator
- c) Output generator
- d) Accurate generator

Answer: b

Explanation: Precision generators are one which generates output voltage much closer to the true value.

5. Why zener diodes are provided in dc supply?

- a) For forward conduction
- b) For reverse conduction
- c) For reference voltage
- d) For increasing amplitude

Answer: c

Explanation: Zener diodes in dc power supplies are used for providing a reference voltage used for comparison.

6. Stability of output voltage is entirely depended on \_\_\_\_\_

- a) Stability of transformer
- b) Stability of zener diode
- c) Quality of wires
- d) Capacitor values

Answer: b

Explanation: Stability of zener diodes used is an important factor in determining the stability of output voltage in dc power supply.

7. For excellent stability, the zener diode is kept in temperature controlled casket.

- a) True
- b) False

Answer: a

Explanation: Zener diode is kept on temperature controlled casket due to its low temperature coefficient which may lead to less stability.

8. For instrumentation system, precision variable voltage-reference system is necessary.

- a) True
- b) False

Answer: a

Explanation: Precision variable voltage reference system is used for comparing voltage with a reference voltage and can be used in the instrumentation system.

9. Which of the following can be used as a comparator?

- a) Zener diode
- b) Diode
- c) Operational amplifier
- d) All of the mentioned

Answer: c

Explanation: Operational amplifier can be used as a comparator circuit.



10. Which of the following are not the standard value of Zener diodes?

- a) 5.1 V
- b) 5.6 V
- c) 5.8V
- d) 6.2V

Answer: c

Explanation: Standard values of zener voltages are 5.1V, 5.6V, 6.2V and 9.1V etc.

11. What is IC723?

- a) A voltage regulator
- b) A full-wave rectifier
- c) A half-wave rectifier
- d) A clipper

Answer: a

Explanation: The IC 723 is a voltage regulator, which can act as both a low voltage regulator as well as a high voltage regulator. Output can be set between 7-37 volts. 7 volts is the reference starting voltage.

12. Consider the circuit shown below where the breakdown voltage of the diode is 5V. Source voltage varies between 6V to 12V.

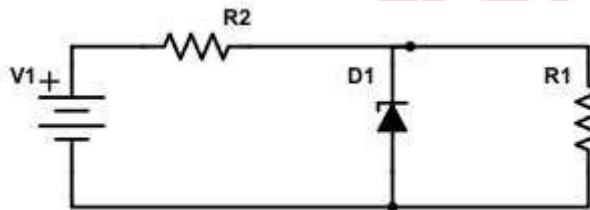

Find the maximum current through the R2, given that R1=2kΩ and R2=5kΩ.

- a) 3.5 mA
- b) 1 mA
- c) 1.4mA
- d) 0.2 mA

Answer: c

Explanation: Source current is  $I = \frac{V_S - V_Z}{R_2}$   
Thus here I is maximum when  $V_S$  is maximum.

$$I = \frac{12-5}{5000} = 1.4 \text{ mA.}$$

13. For a Zener diode shunt regulator, the source current is  $I_S$ , the Zener diode current is  $I_Z$  and the load current is  $I_L$ . The source voltage is  $V_S$ , Zener voltage is  $V_Z$  and load voltage is  $V_L$ . The load resistance is  $R_L$ . What is the correct option for the safe operation of the diode?

- a)  $I_S = I_Z + I_L$
- b)  $I_S \leq I_{Zmax} + I_L$
- c)  $I_S \leq I_{Zmin} + I_L$
- d)  $V_L = V_Z$

Answer: b

Explanation: For proper operation, the current through  $R_S$  should be at least equal to the sum of  $I_{Zmin}$  a specified load current.  $I_S \geq I_{Zmin} + I_L$

For safe operation of the diode,  $I_S \leq I_{Zmax} + I_L$ .

14. What is line regulation?

- a) The process of keeping Zener diode voltage constant inspite of changes in AC supply
- b) The process of keeping load voltage constant irrespective of the fluctuation in AC supply or the line voltage
- c) The process of keeping load voltage constant irrespective of fluctuation in load current
- d) The process of keeping Zener current constant irrespective of fluctuation in AC supply

Answer: b

Explanation: Line regulation is the process of keeping the load voltage constant, irrespective of fluctuation in AC supply or the line voltage. In line regulation, the load current is considered constant.

15. What is load regulation?

- a) The process of keeping the load voltage constant irrespective of any change in AC supply
- b) The process of keeping the load voltage constant irrespective of variations in load current
- c) The process of keeping load voltage constant irrespective of variations in source current
- d) The process of keeping load current constant irrespective of variations in AC supply

Answer: b

Explanation: Load regulation is the process of keeping  $V_O$  constant irrespective of variations in load current. The line voltage is taken to be constant during load regulation.

16. Find the power rating of the diode in the given circuit. The breakdown voltage of the diode is 5V.

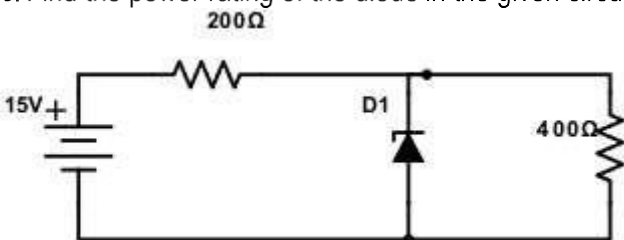

- a) 200 mW
- b) 125 mW
- c) 250 mW
- d) 300 mW

Answer: c

Explanation: Source current  $I_S = 15-5/200 = 0.05A = 50 \text{ mA}$

The power rating of the diode is the maximum power it can dissipate which occurs when the load is disconnected because then the whole current flows into the diode.

Hence maximum power rating is  $P = V_Z \times I_Z = 5 \times 50 = 250 \text{ mW}$ .

17. In a power supply, the output voltage can vary due to multiple reasons. Which of these is not true if it is found that the output voltage is constant?

- a) The voltage stability factor is very high
- b) The output resistance is zero
- c) The temperature coefficient is zero
- d) The voltage stability factor is very small

Answer: a

Explanation: In a power supply, the output voltage can vary due to changes in AC supply, load current and the temperature.

$$V_O = f(V_S, I_L, T)$$

$$\Delta V_O = S_V \cdot \Delta V_S + R_O \Delta I_L + S_T \Delta T.$$

18. Consider the op-amp circuit shown.

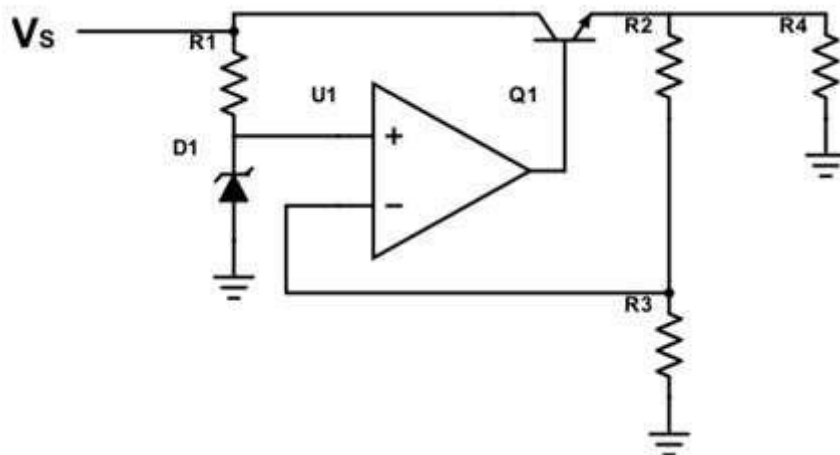

The breakdown voltage of the Zener is 5V.  $\beta$  for the transistor is 100.  $R_1=10k\Omega$ ,  $R_2=90k\Omega$ ,  $R_3=30k\Omega$ ,  $R_4=50k\Omega$ . Calculate the total output voltage.

- a) 20V

- b) 30V
- c) 5V
- d) 50V

Answer: a

Explanation:  $V_O = V_Z(1+R_2/R_3) = 5(1+90/30) = 5 \times 4$   
 $V_O = 20V.$

19. In the Zener controlled series regulator shown below, find the current through the Zener diode.

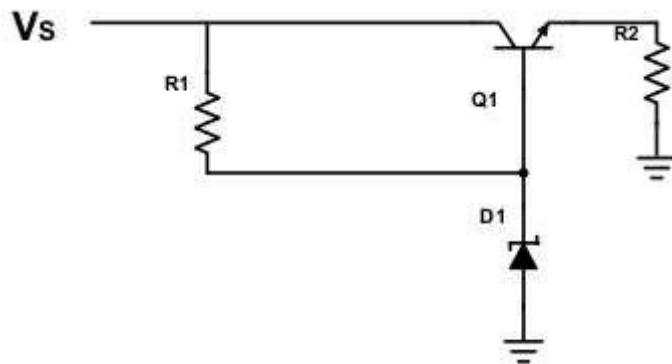

Given that the Zener diode breakdown voltage is 5V, the source voltage is 15V, the output voltage is 10V,  $R_4 = 2k\Omega$ ,  $\beta=99$ ,  $R_1=2k\Omega$ .

- a) 5.05 mA
- b) 4.95 mA
- c) 3.33 mA
- d) 0

Answer: b

Explanation:  $I_E = I_L = (100)I_B$

$I_B = 10/100 \times 2000 = 0.05 \text{ mA}$

Current through  $R_1 = I_B + I_Z = I_1$

$I_Z = I_1 - I_B = 15 - 5/2k - 0.05 = 5 - 0.05 = 4.95 \text{ mA}.$

20. Consider the circuit shown and find the percentage increase in power dissipation of the transistor if the source voltage increases by 10%.

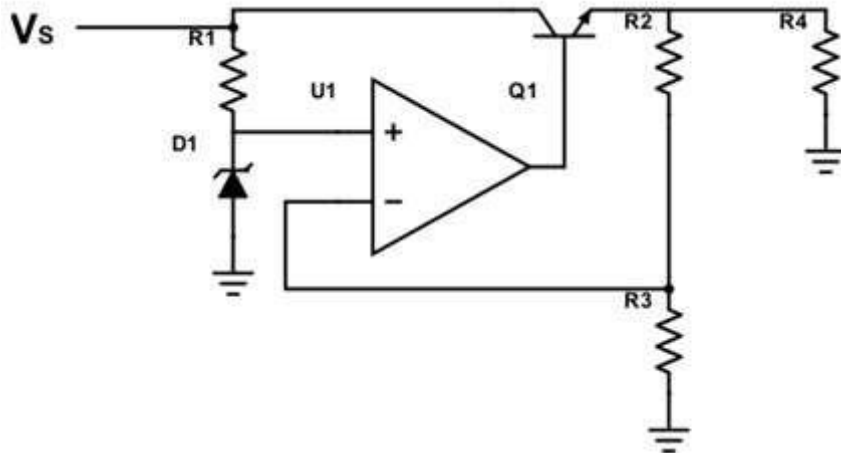

Given that the breakdown voltage is 5V,  $R1=10k\Omega$ ,  $R2=100k\Omega$ ,  $R3=200k\Omega$ ,  $R4=10\Omega$ . The source voltage  $V_S=25V$ .

- a) 10%
- b) 20.22%
- c) 14.28%
- d) 15.66%

Answer: c

Explanation: Originally,  $V_{CE} = 25 - 5 \times \frac{3}{2} = 17.5V$   
 $I_C = 7.5/10 = 0.75A$   
 $V_{OUT}$  and  $I_C$  do not change, only  $V_{CE}$  changes.  
 10% increase in  $V_S$  means now  $V_S = 110/100 \times 25 = 27.5V$   
 $V_{CE} = 20V$   
 Power initially  $P_1 = 17.5 \times 0.75 = 13.125W$   
 Power finally  $P_2 = 20 \times 0.75 = 15W$   
 Power increase % =  $\frac{15 - 13.125}{13.125} \times 100 = 14.28\%$ .

21. The following is a shunt regulator. Find maximum power dissipation of the Zener diode and transistor, given that the source voltage varies from 20-40V, the Zener breakdown voltage is 5V, the output voltage is 10V, the resistance  $R_1=50\Omega$ ,  $R_2=20k\Omega$ ,  $\beta=99$ ,  $V_{BE}=0.5V$ .

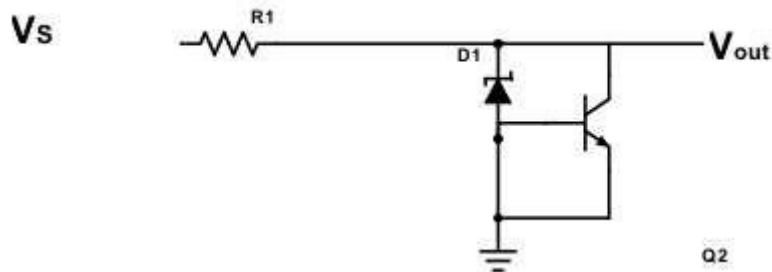
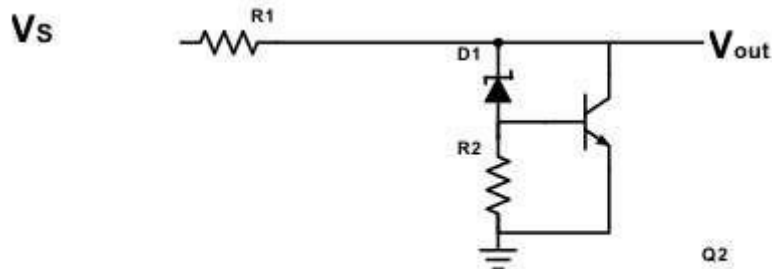

- a)  $P_{\text{Transistor}} = 5.12 \text{ W}$ ,  $P_{\text{Zener}} = 0.051 \text{ W}$
- b)  $P_{\text{Transistor}} = 0.41 \text{ W}$ ,  $P_{\text{Zener}} = 0.57 \text{ W}$
- c)  $P_{\text{Transistor}} = 5.94 \text{ W}$ ,  $P_{\text{Zener}} = 0.057 \text{ W}$
- d)  $P_{\text{Transistor}} = 6.22 \text{ W}$ ,  $P_{\text{Zener}} = 5.66 \text{ W}$

Answer: c

Explanation: Output voltage = 10V = VCE

Current across  $R_1 = \frac{V_S - V_O}{R_1}$

For maximum power dissipation, supply is maximum

$$I = \frac{40 - 10}{50} = 0.6 \text{ A}$$

$$\text{Current } I = I_Z + I_C = I_B + \beta I_B = 100 I_B$$

$$I_B = 6 \text{ mA}$$

$$I_C = 0.594 \text{ A}$$

$$P_{\text{Transistor}} = 10 \times 0.594 = 5.94 \text{ W}$$

$$P_{\text{Zener}} = 10 - 0.5 \times 6 \text{ mA} = 57 \text{ mA} = 0.057 \text{ W}$$

22. What is not related to a transistorized series regulator?

- a) The output can be varied by using a variable resistor
- b) The output is independent of temperature
- c) The overload and short circuit protection is not required
- d) The circuit has negative feedback responsible for regulation

Answer: c

Explanation: In a transistorized series regulator, the Zener diode maintains emitter voltage. An increase in output is canceled by a decrease in the output. The circuit has negative feedback for this regulation. The output may be varied by using a variable resistor and change in output due to temperature due to the Zener diode is canceled by the change in  $V_{BE}$  of the transistor. However, when the load is reduced, or an accidental short-circuit occurs, overload and a short circuit occurs, and protection is needed to prevent that.

23. In a transistorized series regulator, how is the overload and short-circuit protection provided?

- a) By the use of a thermistor
- b) By using two additional diodes and a current sensing resistor to protect the series transistor
- c) By using a diode and an additional resistor to protect the transistor
- d) By using a diode along with a capacitor of a small capacitance value in series

Answer: b

Explanation: Series transistor can be protected by connecting two additional diodes and a current sensing resistor to the circuit. When the load current is smaller, the diode is off and load current is through the transistor and the new resistor. When the load current increases, the voltage drop across the new resistor increases and soon the diodes start conduction. A limiting current flows through the transistor.

24. What is the output of the IC 7924?

- a) 12V
- b) -12V
- c) 24V
- d) -24V

Answer: d

Explanation: The IC of series 78xx and 79xx are fixed voltage regulators, wherein the 78 represents those with a positive output and 79 is for those with a negative output. The xx value represents the magnitude of the output voltage being achieved. For proper operation, the input voltage should be at least 2V greater than the output voltage.

25. In the IC 7805, what is the minimum input voltage for proper functioning?

- a) 5V
- b) 6V
- c) 7V
- d) 8V

Answer: c

Explanation: For a fixed voltage IC regulator, the input voltage should be at least 2V greater than the output voltage. A minimum voltage of 2V should be allowed to drop in the internal circuit of the IC.

26. Which is not considered as a linear voltage regulator?

- a) Fixed output voltage regulator
- b) Adjustable output voltage regulator
- c) Switching regulator
- d) Special regulator

Answer: c

Explanation: In linear regulator's the impedance of active element may be continuously varied to supply a desired current to the load. But in the switching regulator, a switch is turned on and off.

27. What is the dropout voltage in a three terminal IC regulator?

- a)  $|V_{in}| \geq |V_o| + 2v$
- b)  $|V_{in}| < |V_o| - 2v$
- c)  $|V_{in}| = |V_o|$
- d)  $|V_{in}| \leq |V_o|$

Answer: a

Explanation: The unregulated input voltage must be atleast 2V more than the regulated output voltage. example, if  $V_o = 5V$ , then  $V_{in} = 7V$ .

28. To get a maximum output current, IC regulation are provided with

- a) Radiation source
- b) Heat sink
- c) Peak detector
- d) None of the mentioned

Answer: b

Explanation: The load current may vary from 0 to rated maximum output current. To maintain this condition, the IC regulator is usually provided with a heat sink; otherwise it may not provide the rated maximum output current.



29. For the given circuit, let  $V_{EB(ON)}=1\text{v}$ ,  $\beta= 15$  and  $I_O=2\text{mA}$ . Calculate the load current

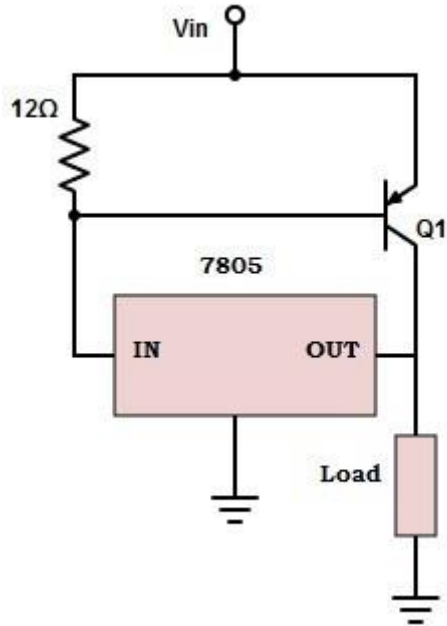

- a)  $I_L = 23.45\text{A}$
- b)  $I_L = 46.32\text{A}$
- c)  $I_L = 56.87\text{A}$
- d)  $I_L = 30.75\text{A}$

Answer: d

Explanation: The equation for load current,  $I_L = [(\beta+1)I_O] - [\beta \times (V_{EB(ON)}/R_1)] = [(15+1) \times 2] - [15 \times (1\text{v}/12 \Omega)] = 32 - 1.25 = 30.75\text{A}$ .

30. Which type of regulator is considered more efficient?

- a) All of the mentioned
- b) Special regulator
- c) Fixed output regulator
- d) Switching regulator

Answer: d

Explanation: The switching element dissipates negligible power in either on or off state. switching regulator is more efficient than the linear regulators.

31. State the reason for thermal shutdown of IC regulator?

- a) Spikes in temperature
- b) Decrease in temperature
- c) Fluctuation in temperature
- d) Increase in temperature

Answer: d

Explanation: The IC regulator has a temperature sensor (built-in) which turn off the IC, when it becomes too hot (usually 125oC-150oC). The output current will drop and remains there until the IC has cooled significantly.

32. Find the difference between output current having a load of 100Ω and 120Ω for 7805 IC regulator. Consider the following specification: Voltage across the load = 5v; Voltage across the internal resistor= 350mv.

- a) 8.4mA
- b) 7mA
- c) 9mA
- d) 3.4mA

Answer: a

Explanation: Given the voltage across the internal resistor to be 350mv, which is less than 0.7v. Hence the transistor in 7805 is off.

When load = 100Ω,  $I_L = I_O = I_i = 5v/100 \Omega = 50mA$

When load=120Ω,  $I_O = 5v/120 \Omega = 41.6mA$ .

So, the difference between the output voltage = 50-41.6mA = 8.4mA.

33. The change in output voltage for the corresponding change in load current in a 7805 IC regulator is defined as

- a) All of the mentioned
- b) Line regulation
- c) Load regulation
- d) Input regulation

Answer: c

Explanation: Load regulation is defined as the change in output voltage for a change in load current and is also expressed in millivolts or as a percentage of output voltage.

34. An IC 7840 regulator has an output current =180mA and internal resistor =10Ω. Find the collector current in the output using the transistor specification:  $\beta=15$  and  $V_{EB(ON)} = 1.5v$ .

- a) 270mA
- b) 450mA
- c) 100mA
- d) 50mA

Answer: b

Explanation: The collector current from transistor,  $I_C = \beta I_B$   
 Where,  $I_B = I_O - (V_{EB(ON)}/R_1) = 180mA - (1.5v/10\Omega) = 0.03A$ .  
 Therefore,  $I_C = 15 \times 0.03 = 0.45A = 450mA$ .

35. How the average temperature coefficient of output voltage expressed in fixed voltage regulator?

- a) millivolts/oC
- b) millivoltsoC
- c) None of the mentioned
- d) oC/ millivolts

Answer: a

Explanation: The temperature stability or average temperature coefficient of output voltage, is the change in the output voltage per unit change in temperature and expressed in millivolts/oC.

36. Calculate the output voltage for LM314 regulator.  
 (Assume  $V_{REF} = 1.25v$ )

is very small

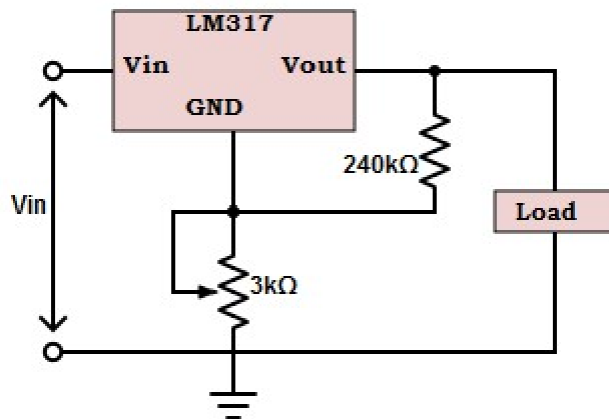

- a) 17.17v
- b) 34.25v
- c) 89.34v
- d) 23.12v

Answer: a

Explanation: The output voltage,  $V_O = V_{REF} [1 + (R_2/R_1)] + (I_{ADJ} \times R_2) = 1.25V_{in} \times [1 + (3k\Omega/240\Omega)] + (100\mu A \times 3k\Omega) = 16.875 + 0.3$ .  
 $\Rightarrow V_O = 17.17v$ .

37. Compute the input voltage of 7805c voltage regulator with a current source that will deliver a 0.725A current to 65Ω, 10w load. (Assume reference voltage =5v)

- a) Vin = 84v
- b) Vin = 34v
- c) Vin = 54v
- d) Vin = 64v

Answer: c

Explanation:  $V_O = V_{REF} + V_L = V_{REF} + (I_L \times R_L) = 5v + (0.725A \times 65\Omega) = 52.125v$

=> Input voltage,  $V_{in} = V_O + \text{dropout voltage} = 52.125v + 2v.$

=>  $V_{in} = 54v.$

38. Which of the following is not a characteristic of adjustable voltage regulators?

- a) Non-versatile
- b) Better performance
- c) Increased reliability
- d) None of the mentioned

Answer: a

Explanation: Adjustable voltage regulators are versatile; it has improved over-load protection allowing greater output current over operating temperature range.

39. What is done in switching regulators to minimize its power dissipation during switching?

- a) Uses external transistor
- b) Uses 1mH choke
- c) Uses external transistor and 1mH
- d) None of the mentioned

Answer: c

Explanation: To minimize power dissipation during switching, the external transistor must be a switching power transistor and a 1mH choke smooth out the current pulses delivered to the load.

40. Fixed voltage regulators and adjustable regulators are often called as

- a) Series dissipative regulators
- b) Shunt dissipative regulators
- c) Stray dissipative regulators
- d) All the mentioned

Answer: a

Explanation: Series dissipative regulators simulate a variable resistance between the input voltage & the load and hence functions in a linear mode.

41. A series switching regulators

- a) Improves the efficiency of regulators
- b) Improves the flexibility of switching
- c) Enhance the response of regulators
- d) All of the mentioned

Answer: a

Explanation: A series switching regulators is constructed such that, a series pass transistor is used as a switch rather than as a variable resistance in linear mode.

42. The switching regulators can operate in

- a) Step up
- b) Step down
- c) Polarity inverting
- d) All the mentioned

Answer: d

Explanation: The switching regulators can operate in any one of the three modes depending on the way in which the components are connected.

43. Which among the following act as a switch in switching regulator?

- a) Rectifiers
- b) Diode
- c) Transistors
- d) Relays

Answer: c

Explanation: A transistor is connected as power switch and is operated in the saturated mode. Thus, pulse generator output alternatively turns the switch ON and OFF in switching regulator.

44. What should be the frequency range of pulse generator?

- a) 250 kHz
- b) 40 kHz
- c) 120 kHz
- d) 20 kHz

Answer: d

Explanation: The most effective frequency range for pulse generator for optimum efficiency and component size is 20kHz.

45. Filter used in switching regulator's are also as called

- a) DC – AC transformers
- b) AC – DC transformers
- c) DC transformer
- d) AC transformer

Answer: c

Explanation: Filter converts the pulse waveform from the output of the switch into a dc voltage. Since this switching mechanism allows a conversion similar to transformers, the switching regulators is often referred to as a DC transformer.

46. Find the value of Rsc, L and Co for a  $\mu$ A7840 switching regulator to provide +5 v at 3A, using the following specifications: toff= 24 $\mu$ s, ripple voltage = 400mA and ton=26 $\mu$ s.

- a) Rsc = 55 m $\Omega$  , L = 25 $\mu$ H & Co = 750 $\mu$ F
- b) Rsc = 550 m $\Omega$  , L = 25 $\mu$ H & Co = 75 $\mu$ F
- c) Rsc = 650 m $\Omega$  , L = 25 $\mu$ H & Co = 65 $\mu$ F
- d) Rsc = 720 m $\Omega$  , L = 25 $\mu$ H & Co = 250 $\mu$ F

Answer: a

Explanation: Peak current,  $I_{pk} = 400\text{mA} \times 1.5$  (since  $I_{pk} = 1.5$  A for peak current)

$\therefore R_{sc} = 0.33\text{ohm}/I_{pk} = 0.33\text{ohm}/6 = 0.055\text{ohm}$ .

$\Rightarrow L = [(V_o + V_p) / I_{pk}] \times t_{off} = [(5 + 1.25) / 6] \times 24 \times 10^{-6} = 25\mu\text{H}$ .

$\Rightarrow C_o = [I_{pk} (T_{on} + T_{off})] / [8 \times V_{ripple}] \cdot T = [ton + toff] = 26\mu\text{s} + 24\mu\text{s} = 50\mu\text{s}$

$\Rightarrow C_o = [(6 \times 50\mu\text{s})] / (8 \times 50\text{mA}) = 7.5 \times 10^{-4} = 750\mu\text{F}$ .

47. Calculate the efficiency of the step down switching regulator given the input voltage  $V_{in} = 13.5\text{v}$  and output voltage = 6v. Assume the saturating Voltage  $V_s = 1.1\text{v}$  and the forward voltage drop  $V_d = 1.257\text{v}$

- a)  $\eta = 75\%$
- b)  $\eta = 48.5\%$
- c)  $\eta = 63.9\%$
- d)  $\eta = 80.5\%$

Answer: d

Explanation: Efficiency of the step down switching regulator,  $\eta = \{[(V_{in} - V_s + V_d)] / [V_{in}]\} \times (V_o) / [(V_o + V_d)] = \{[(13.5\text{v} - 1.1\text{v} + 1.257\text{v}) / 13.5\text{v}]\} \times [(6 / (6 + 1.257)) \Rightarrow \text{Efficiency of switching regulator, } \eta = (1.012 \times 0.7955) \times 100 = 0.8051 \times 100 = 80.5\%$ .

48. Zener diodes are also known as

- a) Voltage regulators
- b) Forward bias diode
- c) Breakdown diode
- d) None of the mentioned

Answer: c

Explanation: Zener diodes are used as voltage regulators but they aren't called voltage regulators. are called breakdown diodes since they operate in breakdown region.

49. Which of the following is true about the resistance of a Zener diode?

- a) It has an incremental resistance
- b) It has dynamic resistance
- c) The value of the resistance is the inverse of the slope of the i-v characteristics of the Zener diode
- d) All of the mentioned

Answer: d

Explanation: All of the statements are true for the resistance of the zener diode.

